

AE-200AN

MACHINE FRAME & MISCELLANEOUS COVER COMPONENTS

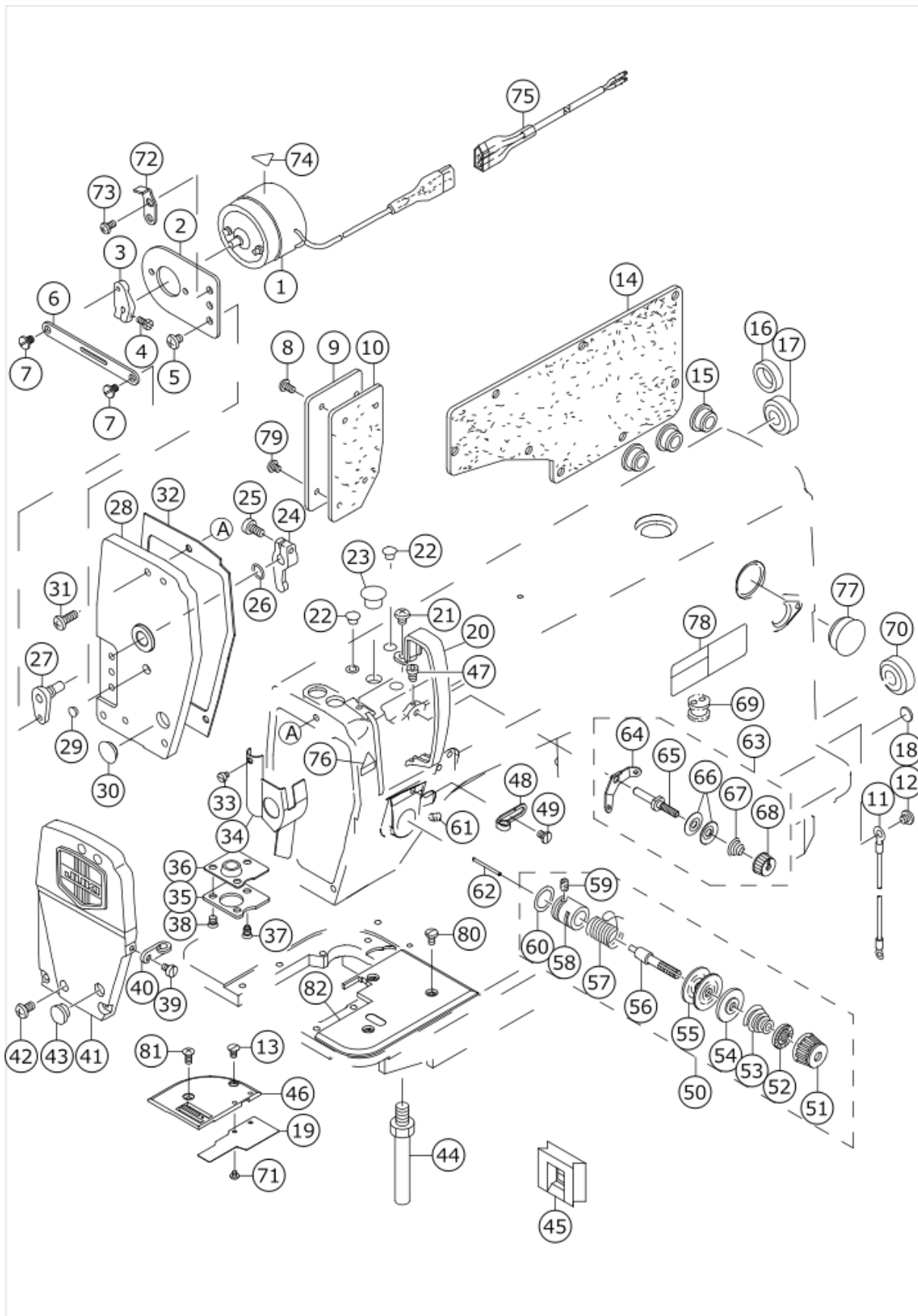

No.	品番	品名	備考	子部品	消耗品	個数
1	11281656	SOLENOID ASM.				1.00
2	11275807	SOLENOID BASE				1.00
3	11275708	SOLENOID ARM				1.00
4	SS6111040SP	SCREW 11/64-40 L=9.5				1.00
5	SS4120615SP	SCREW 3/16-28 L=6				1.00
6	11275609	SOLENOID LINK				1.00
7	SD0550212TP	HINGE SCREW D=5.5 H=2.1				2.00
8	SS4120915SP	SCREW 3/16-28 L=9				3.00
9	11255809	SIDE COVER				1.00
10	11200607	GASKET				1.00
11	40090869	EARTH CORD ASSY				1.00
12	SS4120615SP	SCREW 3/16-28 L=6				1.00
13	SS1110710SP	SCREW 11/64-40 L=7				1.00
14	11003308	GASKET				1.00
15	TA1470704R0	RUBBER PLUG				3.00
16	TA1470702R0	RUBBER PLUG				1.00
17	TA2101002R0	RUBBER PLUG				1.00
18	22901805	GROUND MARK				1.00
19	40098821	THROAT_PLATE_COVER				1.00
20	22900609	THREAD TAKE-UP LEVER COVER				1.00
21	SS4120615SP	SCREW 3/16-28 L=6				1.00
22	TA0850604R0	RUBBER PLUG				2.00
23	TA1250705R0	RUBBER PLUG				1.00
24	11275302	WALKING FOOT ADJUSTING ARM				1.00
25	SS6121010SP	SCREW 3/16-28 L=10				1.00
26	RO069180100	RUBBER RING				1.00
27	11275450	WALKING FOOT ARM SHAFT ASM.				1.00
28	11280351	FACE PLATE BASE ASM.				1.00
29	TA0750404R0	PLUG D=7.5 L=3.5				1.00
30	TA1250406R0	RUBBER PLUG D=12.5 L=4				1.00
31	SS4121415SP	SCREW 3/16-28 L=14				3.00
32	11200201	GASKET				1.00
33	SS6080410SP	SCREW 1/8-44 L=4				1.00
34	22900757	FACE PLATE OIL SHIELD ASM.				1.00
35	11200300	PRESSER BAR SUPPORT				1.00
36	11200409	GASKET				1.00
37	11200805	PRESSER BAR SUPPORT SCREW B				1.00
38	SS1120710SP	SCREW 3/16-28 L=6.5				2.00
39	SS6110610TP	SCREW 11/64-40 L=6				1.00
40	11331402	ARM THREAD GUIDE, B				1.00
41	11280252	FACE PLATE ASM.				1.00
42	SS4120915SP	SCREW 3/16-28 L=9				2.00
43	TA1250406R0	RUBBER PLUG D=12.5 L=4				1.00
44	22901003	BED SCREW STUD				4.00
45	22935407	BED OIL SHIELD RUBBER				1.00
46	40098870	THROAT_PLATE_B(THICK_USE)				1.00
47	SS4120615SP	SCREW 3/16-28 L=6				1.00
48	22920508	ARM THREAD GUIDE A				1.00
49	22921001	SCREW				1.00
50	11257359	THREAD TENSION ASM.				1.00

51	22921308	THREAD TENSION NUT		*		1.00
52	22921407	ROTATION STOPPER		*		1.00
53	22921704	THREAD TENSION SPRING, A		*		1.00
54	22921803	DISK STOPPER		*		1.00
55	22921506	THREAD TENSION DISK		*		2.00
56	22921209	THREAD TENSION POST		*		1.00
57	22921605	THREAD TAKE-UP SPRING		*		1.00
58	11220209	TENSION POST SOCKET		*		1.00
59	SS8090410SP	SCREW 9/64-40 L=3.5		*		1.00
60	RO133170100	RUBBER RING		*		1.00
61	SS8150822TP	SCREW 15/64-28 L=8				1.00
62	B3118552C00	TENSION RELEASE PIN C				1.00
63	22945463	THREAD TENSION ASM. ,NO.1				1.00
64	22945414	THREAD TENSION POST		*		1.00
65	22945604	THREAD TENSION GUIDE		*		1.00
66	22945802	THREAD TENSION DISK		*		2.00
67	22945505	THREAD TENSION SPRING		*		1.00
68	22945703	THREAD TENSION NUT		*		1.00
69	11100104	MAGNET CORD RUBBER				1.00
70	TA2101002R0	RUBBER PLUG				1.00
71	SS4060310SP	SCREW 3/32-56 L=2.5				2.00
72	11276102	SOLENOID LINK STOPPER				1.00
73	SS4120915SP	SCREW 3/16-28 L=9				2.00
74	CM300300001	HIGH TEMPARATURE CAUTION LABEL 2 (16)				1.00
75	11281755	SOLENOID CABLE ASM.				1.00
76	CM300200001	ATTENTION SEAL				1.00
77	TA2351004R0	RUBBER PLUG				1.00
78	CM301300001	SAFETY LABEL				1.00
79	SS4120615SP	SCREW 3/16-28 L=6				1.00
80	SS7110710SP	SCREW 11/64-40 L=7				3.00
81	SS2110915SP	SCREW 11/64-40 L=8.5				1.00
82	40098869	BED_UPPER_PLATE				1.00

MAIN SHAFT & THREAD TAKE-UP LEVER COMPONENTS

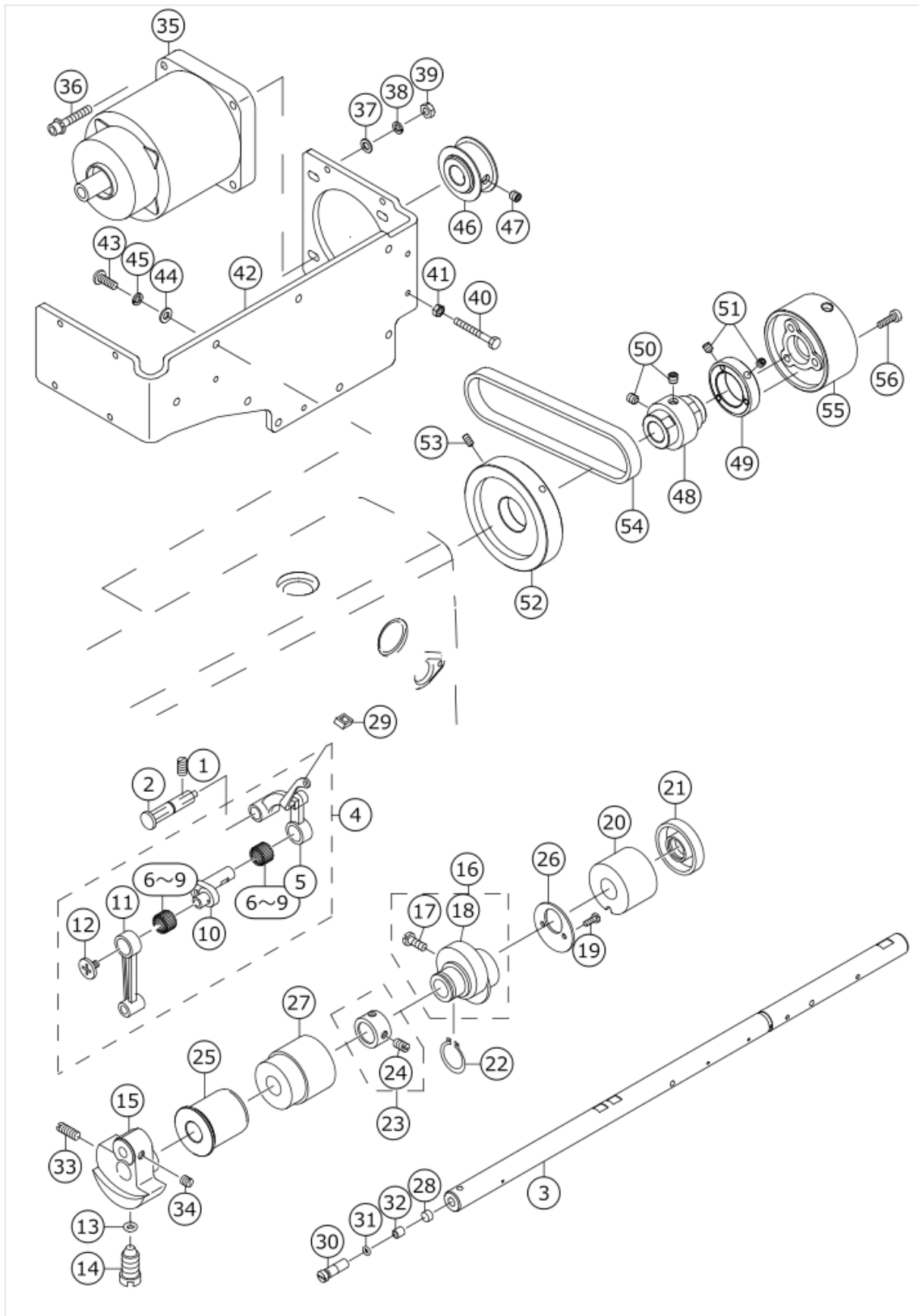

No.	品番	品名	備考	子部品	消耗品	個数
1	SS8151150SP	SCREW 15/64-28 L=10.5				1.00
2	22919559	THREAD TAKE-UP CRANK SHAFT ASM				1.00
3	11202009	MAIN SHAFT				1.00
4	11039070	THREAD TAKE-UP LEVER ASM.				1.00
5	11039062	THREAD TAKE-UP LEVER ASM.		*		1.00
6	B1905541A00	NEEDLE BEARING, A	SELECTIVE PART	*		2.00
7	B1905541B00	NEEDLE BEARING	SELECTIVE PART	*		2.00
8	B1905541C00	NEEDLE BEARING	SELECTIVE PART	*		2.00
9	B1905541D00	NEEDLE BEARING	SELECTIVE PART	*		2.00
10	11005204	NEEDLE BAR CRANK		*		1.00
11	B1408552000	NEEDLE BAR CRANK ROD		*		1.00
12	B1903552000	LEFT SCREW		*		1.00
13	RO044240100	RUBBER RING				1.00
14	SS7681650TP	SCREW 9/32-28 L=16				1.00
15	11202173	COUNTERWEIGHT ASM.				1.00
16	22910053	FEED DRIVE ECCENTRIC CAM ASM.				1.00
17	SS6661110SP	SCREW 1/4-40 L=11		*		2.00
18	22910004	FEED DRIVE ECCENTRIC CAM		*		1.00
19	SS4090615SP	SCREW 9/64-40 L=6				2.00
20	11002409	MAIN SHAFT BUSHING, REAR				1.00
21	11002508	OIL SEAL				1.00
22	RC1850001KP	SNAP RING 18.5				1.00
23	22904155	MAIN SHAFT THRUST COLLAR ASM.				1.00
24	SS8660610TP	SCREW 1/4-40 L=6		*		2.00
25	11202207	MAIN SHAFT BUSHING, FRONT				1.00
26	22910103	THRUST COLLAR				1.00
27	11202306	BUSHING, INTERMEDIATE				1.00
28	B1226552000	ROLLER FELT				1.00
29	22919203	OIL PROTECTING RUBBER				1.00
30	B1213552000A	OIL ADJUSTING PIN				1.00
31	RO029180100	RUBBER RING				1.00
32	B1215552000	OIL ADJUSTING COLLAR				1.00
33	SS8681650TP	SCREW 9/32-28 L=16				1.00
34	SS8660610TP	SCREW 1/4-40 L=6				2.00
35	40050265	AC_SERVO_MOTOR				1.00
36	SL6053092TN	SCREW				4.00
37	WP0531000SD	WASHER M5				4.00
38	WS0510002KP	SPRING WASHER 5.1X9.2X1.3				4.00
39	NM6050001SP	NUT M5				4.00
40	SM9043553TN	SCREW M4 L=35				2.00
41	NM6040001SP	NUT M4X0.7				2.00
42	40088033	MOTOR_BASE_PLATE				1.00
43	SS4121415SP	SCREW 3/16-28 L=14				8.00
44	WP0501016SD	WASHER 5X10.5X1				8.00
45	WS0510002KP	SPRING WASHER 5.1X9.2X1.3				8.00
46	40088138	MOTOR_SHAFT_PULLEY				1.00
47	SM8060612TP	SCREW M6 L=6				2.00
48	40088139	MAIN_SHAFT_PULLEY				1.00
49	40088140	FLYING WHEEL COLLAR				1.00
50	SM8060612TP	SCREW M6 L=6				2.00

51	SM8050612TP	SCREW M5X6				2.00
52	40088141	FLANGE				1.00
53	SM8040802TP	SCREW M4X8				2.00
54	40088142	TIMING_BELT				1.00
55	40088143	HAND_WHEEL				1.00
56	SM6041410SC	SCREW M4X0.7 L=14				3.00

NEEDLE BAR, UPRIGHT SHAFT & HOOK DRIVING SHAFT COMPONENTS

TS

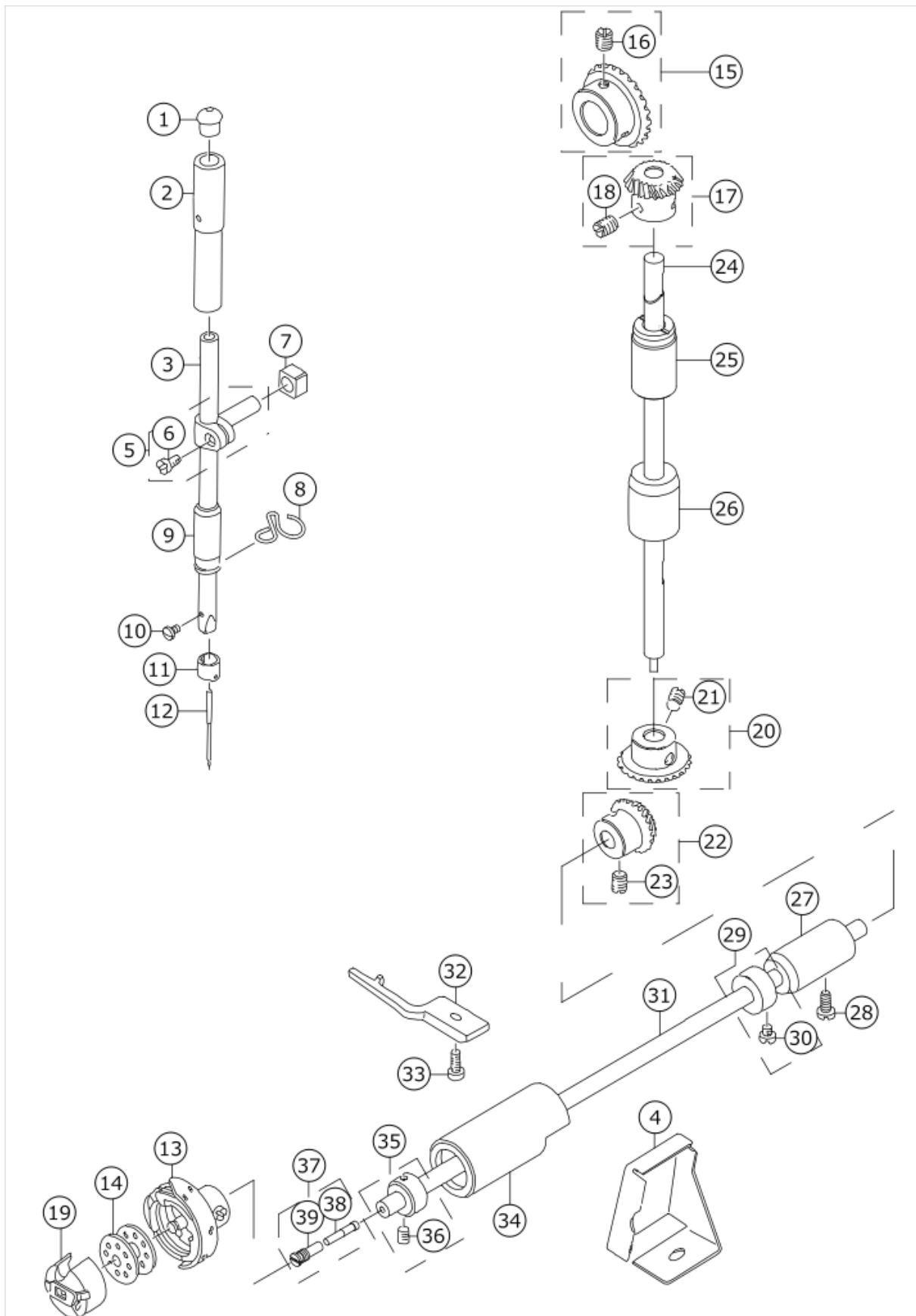

No.	品番	品名	備考	子部品	消耗品	個数
1	22901409	NEEDLE BAR UPPER BUSH CAP				1.00
2	22906101	NEEDLE BAR BUSHING, UPPER				1.00
3	B1401522A00A	NEEDLE BAR (A)				1.00
4	22942601	OIL SHIELD				1.00
5	22906457	NEEDLE BAR HOLDER ASM.				1.00
6	SS6090670TP	SCREW 9/64-40 L=6		*		1.00
7	B1414555000	SLIDE BLOCK				1.00
8	22920805	NEEDLE BAR THREAD GUIDE				1.00
9	22906200	NEEDLE BAR BUSHING, LOWER				1.00
10	SS7080510TP	SCREW 1/8-44 L=4.5				1.00
11	11331204	NEEDLE BAR THREAD GUIDE				1.00
12	MDB100B1100	NEEDLE DBX1 #11				1.00
13	11038650	HOOK ASM.				1.00
14	22932909	BOBBIN				1.00
15	B13050120A0	GEAR ASM.				1.00
16	SS8660810TP	SCREW 1/4-40 L=8		*		2.00
17	B13061550A0	PINION ASM.				1.00
18	SS8660810TP	SCREW 1/4-40 L=8		*		2.00
19	11038759	BOBBIN CASE ASM.				1.00
20	B13071550A0	GEAR ASM. LARGE				1.00
21	SS8660810TP	SCREW 1/4-40 L=8		*		2.00
22	B13081550A0	PINION ASM.				1.00
23	SS8660810TP	SCREW 1/4-40 L=8		*		2.00
24	22905004	UPRIGHT SHAFT				1.00
25	11203106	BUSHING, UPPER				1.00
26	11004207	UPRIGHT SHAFT BUSHING, LOWER				1.00
27	22916308	HOOK DRIVING SHAFT BUSH, REAR				1.00
28	SS4120915SP	SCREW 3/16-28 L=9				1.00
29	CS0791016SH	THRUST HOLDER D=7.94 W=10				1.00
30	SS6110420TP	SCREW 11/64-40 L=4.8		*		2.00
31	22916001	HOOK DRIVING SHAFT				1.00
32	11038809	BOBBIN CASE HOLDER				1.00
33	SS4110915TP	SCREW 11/64-40 L=9				1.00
34	22916100	HOOK DRIVING SHAFT BUSH, FRONT				1.00
35	CS0790731SH	THRUST COLLAR				1.00
36	SS8110410TP	SCREW 11/64-40 L=3.5		*		2.00
37	22916555	OIL SEAL SCREW ASM.				1.00
38	11015906	OIL WICK		*		1.00
39	B1808552000	OIL SEAL SCREW		*		1.00

HAND LIFTER COMPONENTS

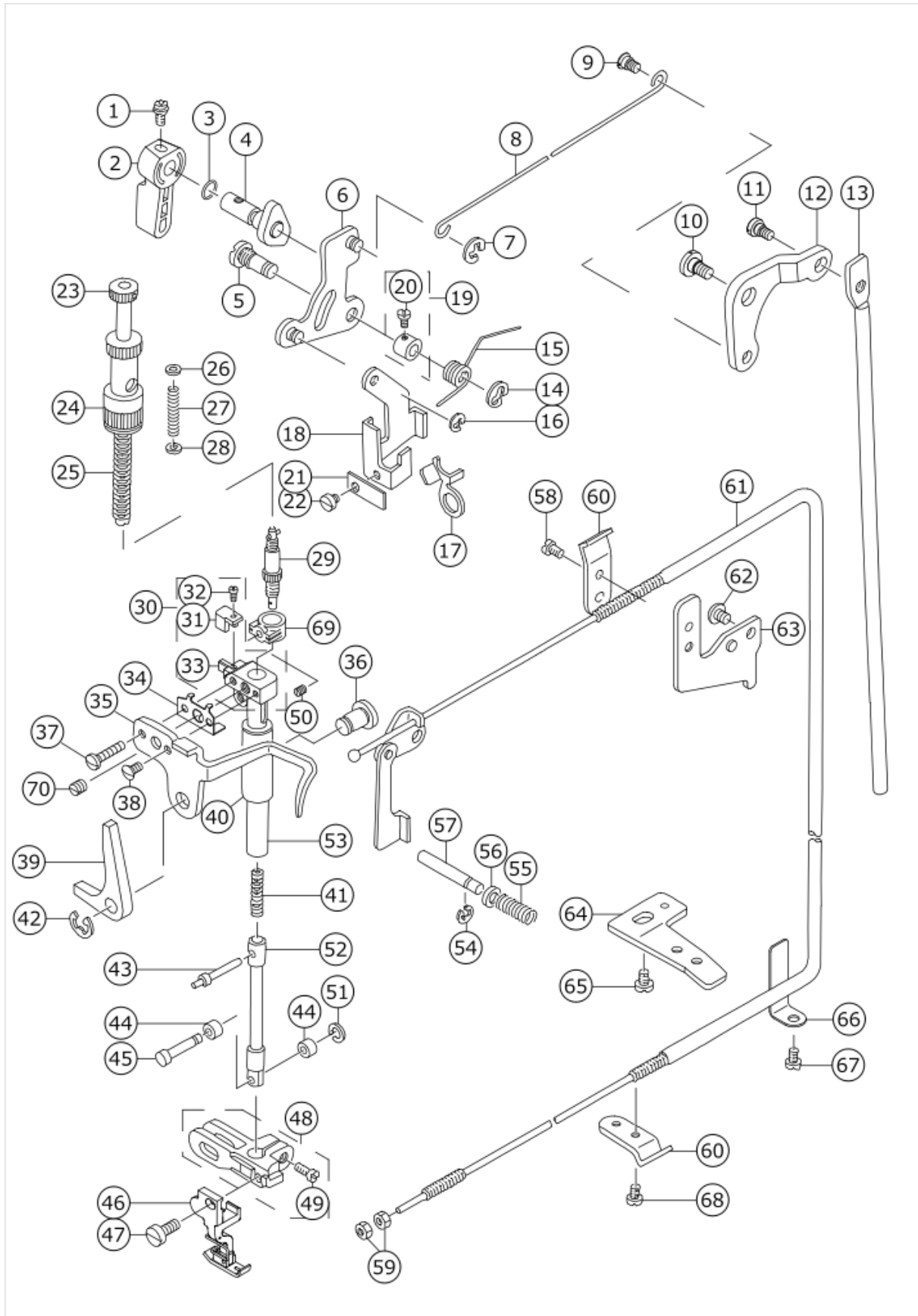

No.	品番	品名	備考	子部品	消耗品	個数
1	B1521555000	SCREW				1.00
2	22907802	HAND LIFTER				1.00
3	RO037180100	RUBBER RING				1.00
4	22908552	HAND LIFTER CAM ASM.				1.00
5	11205218	LIFTING LEVER LINK SHAFT				1.00
6	11006350	HAND LIFTER LINK				1.00
7	RE0500000K0	E-RING				1.00
8	22908305	KNEE LIFTER SIDE ROD				1.00
9	22908909	HINGE SCREW				1.00
10	SD0720331SP	HINGE SCREW D=7.24 H=3.3				1.00
11	SD0600322SD	HINGE SCREW D=6 H=3.2				1.00
12	11205309	LIFTING LEVER LINK				1.00
13	11205408	CONNECTING ROD				1.00
14	RE0500000K0	E-RING				1.00
15	11230802	SPRING				1.00
16	RE0500000K0	E-RING				1.00
17	11220100	TENSION RELEASE PLATE				1.00
18	11271004	LIFTING LEVER				1.00
19	CS0640611SP	THRUST HOLDER				1.00
20	SS7090620TP	SCREW 9/64-40 L=6.1		*		1.00
21	11271301	PRESSER PLATE				1.00
22	SS6110480SP	SCREW 11/64-40 L=4.3				1.00
23	11204559	PRESSER SPRING REGULATOR ASM.				1.00
24	11204609	NUT				1.00
25	22907406	PRESSER SPRING				1.00
26	WP0650816SP	WASHER				1.00
27	11205002	GUIDE BAR SPRING				1.00
28	WP0661016SP	WASHER				1.00
29	11217353	CAP ASM.				1.00
30	11204161	PRESSER ROD HOLDER ASM.				1.00
31	11204211	BRACKET GUIDE		*		1.00
32	SS4080620TP	SCREW 1/8-44 L=6		*		1.00
33	11204112	PRESSER BAR GUIDE BRACKET		*		1.00
34	11204302	BRACKET PLATE				1.00
35	11271103	PRESSER BAR THREAD GUIDE				1.00
36	11271202	SHAFT PIN				1.00
37	SS7110910TP	SCREW 11/64-40 L=8.5				1.00
38	SS2090810SP	SCREW 9/64-40 L=7.5				1.00
39	11216801	DRIVING PRESSER ARM				1.00
40	11204401	BUSHING				1.00
41	11217601	WALKING FOOT SPRING				1.00
42	RE0400000K0	E-RING 4				1.00
43	11275005	DRIVING BAR PIN				1.00
44	11217213	ROLLER				2.00
45	11217114	ROLLER SHAFT				1.00
46	40088257	COMPENSATING_PRESSER_ASM.				1.00
47	SS6121220TP	SCREW 3/16-28 L=11.5				1.00
48	11215258	PRESSER BAR BASE ASM.				1.00
49	SS6121220TP	SCREW 3/16-28 L=11.5		*		1.00
50	SS8110422TP	SCREW 11/64-40 L=4				1.00

51	RC0260415KP	SNAP RING				1.00
52	11230117	DRIVING BAR				1.00
53	11204013	PRESSER BAR				1.00
54	RE0400000K0	E-RING 4				1.00
55	22920409	THREAD RELEASE PIN SPRING				1.00
56	11220308	THRUST WASHER				1.00
57	11220001	PIN				1.00
58	SS4110515SP	SCREW 11/64-40 L=5				1.00
59	NS6620310SP	NUT 3/16-32				2.00
60	22944508	WIRE PRESSER A				2.00
61	11230562	WIRE TUBE				1.00
62	SS4120615SP	SCREW 3/16-28 L=6				1.00
63	22944607	WIRE PRESSER BASE, UPPER				1.00
64	22962807	WIRE PRESSER BASE B, LOWER				1.00
65	SS7110740TP	SCREW 11/64-40 L=7				1.00
66	22945109	WIRE CABLE SUPPORT				1.00
67	SS4120615SP	SCREW 3/16-28 L=6				1.00
68	SS4110515SP	SCREW 11/64-40 L=5				1.00
69	11205507	PRESSER ROD STOPPER				1.00
70	SS8660610TP	SCREW 1/4-40 L=6				1.00

FEED MECHANISM COMPONENTS

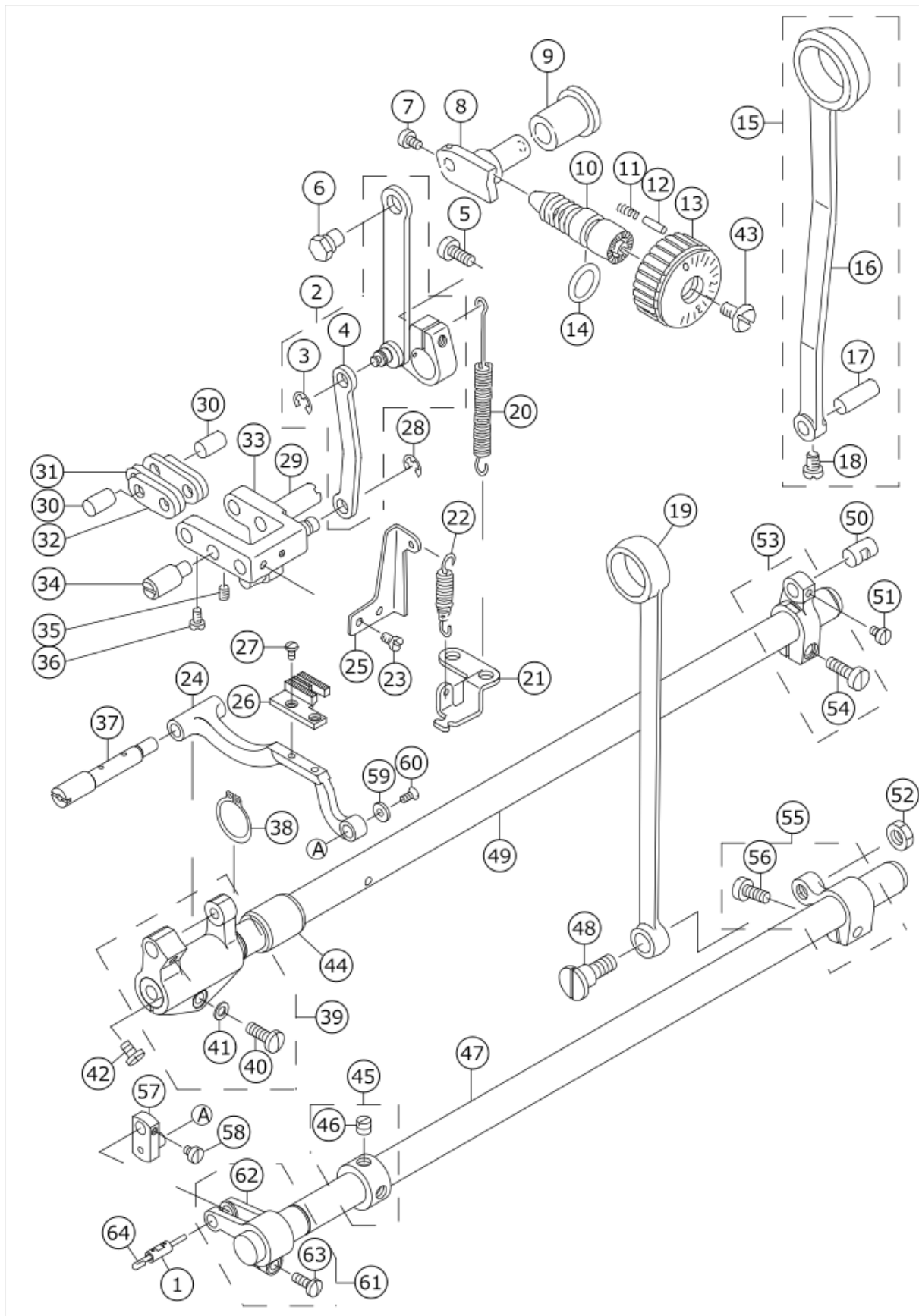

No.	品番	品名	備考	子部品	消耗品	個数
1	B170647000B	LINK SHAFT				1.00
2	11206463	FEED CHANGING ARM ASM.				1.00
3	RE0500000K0	E-RING		*		1.00
4	11206208	CONNECTING ROD B		*		1.00
5	SS6121220TP	SCREW 3/16-28 L=11.5				1.00
6	11206307	FEED REGULATOR PIN				1.00
7	SS6090670TP	SCREW 9/64-40 L=6				2.00
8	11206406	FEED REGULATOR				1.00
9	11273406	FEED REGULATOR BUSHING				1.00
10	22911804	FEED REGULATOR SCREW				1.00
11	22912109	FEED REGULATOR PIN SPRING				1.00
12	22912000	FEED REGULATOR PIN				1.00
13	22940506	FEED DIAL				1.00
14	RO092270200	RUBBER RING				1.00
15	40080424	CONNECTING ROD ASM.				1.00
16	11206000	CONNECTING ROD		*		1.00
17	22911101	WALKING FOOT PIN C		*		1.00
18	SS6090620TP	SCREW		*		1.00
19	11014008	CONNECTING ROD				1.00
20	11010311	FEED REVERSE SPRING				1.00
21	22962203	FEED SPRING HOOK				1.00
22	11091204	ADJUST LINK SPRING				1.00
23	SS4110515SP	SCREW 11/64-40 L=5				2.00
24	18050401	FEED BAR				1.00
25	22941306	REGULATOR LINK SPRING HOOK				1.00
26	22881403	FEED DOG B				1.00
27	SS4080620TP	SCREW 1/8-44 L=6				2.00
28	RE0500000K0	E-RING				1.00
29	40010395	ADJUSTING LINK FULCRUM SHAFT B				1.00
30	22910905	WALKING FOOT PIN A				2.00
31	11008703	WALKING FOOT LINK				2.00
32	11008604	CONNECTING LINK A				2.00
33	22940951	FEED ADJUST LINK ASM.				1.00
34	22910806	ADJUST LINK FULCRUM SHAFT A				1.00
35	SS8150710TP	SCREW 15/64-28 L=7				1.00
36	SS6090620TP	SCREW				2.00
37	22940803	FEED BAR SHAFT				1.00
38	RC0150001KP	RETAINING RING 13.8				1.00
39	22940654	FEED ROCKER ASM.				1.00
40	SS7121410TP	SCREW 3/16-28 L=14		*		1.00
41	WP0480856SP	WASHER 4.8X8.4X0.8		*		1.00
42	SS7110740TP	SCREW 11/64-40 L=7				1.00
43	SS6121860SP	SCREW 3/16-28 L=18				1.00
44	22913008	FEED ROCKER SHAFT BUSHING				1.00
45	22904155	MAIN SHAFT THRUST COLLAR ASM.				1.00
46	SS8660610TP	SCREW 1/4-40 L=6		*		1.00
47	22915201	FEED DRIVING SHAFT				1.00
48	SD1000801SH	HINGE SCREW D=10 H=8				1.00
49	22912901	FEED ROCKER SHAFT				1.00
50	22911002	WALKING FOOT PIN B				1.00

51	SS6090620TP	SCREW				1.00
52	NS6680410SP	NUT 9/32-28				1.00
53	22910350	FEED ROCKER SHAFT CRANK ASM.				1.00
54	SS6121610SP	SCREW 3/16-28 L=15.5		*		1.00
55	22915151	FEED ARM COMPL.				1.00
56	SS6121210SP	SCREW 3/16-28 L=12		*		1.00
57	B1705470000	FEED BAR LINK				1.00
58	SS6090510TP	SCREW 9/64-40 L=5.0				1.00
59	B1715481000	COUNTER-SUNK WASHER				1.00
60	SS1080510SP	SCREW 1/8-44 L=5				1.00
61	40089401	FEED DRIVING ARM ASM.				1.00
62	B1704470000	FEED DRIVING ARM		*		1.00
63	SS7111120TP	SCREW		*		1.00
64	CQ202000000	OIL WICK				0.05

TOP FEED MECHANISM COMPONENTS

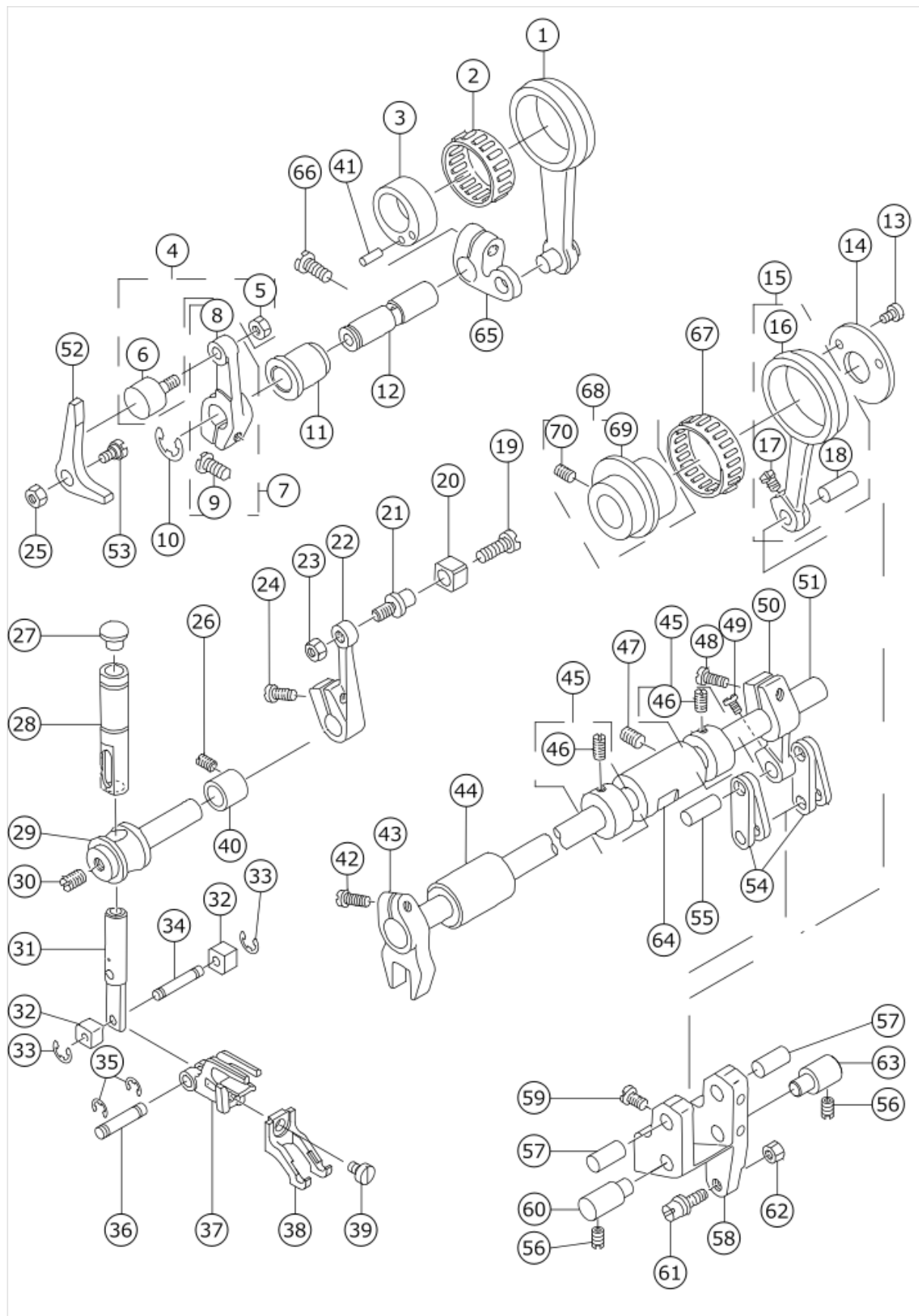

No.	品番	品名	備考	子部品	消耗品	個数
1	11216157	WALKING FOOT DRIVING ROD ASM.				1.00
2	B1609804B00	NEEDLE BEARING				1.00
3	11216009	WALKING FOOT DRIVING CAM				1.00
4	11216751	DRIVING ROLLER ASM.				1.00
5	NM6040001SD	NUT M4		*		1.00
6	11216702	DRIVING ROLLER		*		1.00
7	11216652	VERTICAL ARM ASM. FRONT				1.00
8	11216603	DRIVING ARM, FRONT		*		1.00
9	SS6121250TP	SCREW 3/16-28 L=11.5		*		1.00
10	RE0700000K0	E-RING 7				1.00
11	11216504	DRIVING SHAFT BUSHING				1.00
12	11216405	WALKING FOOT DRIVING SHAFT				1.00
13	SS6090630TP	SCREW 9/64-40 L=6				2.00
14	11210119	THRUST COLLAR				1.00
15	40078218	WALKING FOOT DRIVING ROD ASM.				1.00
16	11210200	WALKING FOOT DRIVING ROD		*		1.00
17	SS7090910TP	SCREW 9/64-40 L=8.5		*		1.00
18	22911101	WALKING FOOT PIN C		*		1.00
19	SS7110570SP	SCREW 11/64-40 L=4.8				1.00
20	11214301	ROLLER				1.00
21	11214202	WALING FOOT HORIZONTAL LOWER				1.00
22	11214103	FEED ROCKER SHAFT CRANK, LOWER				1.00
23	NS6120310SP	NUT 3/16-28				1.00
24	SS6121220TP	SCREW 3/16-28 L=11.5				1.00
25	NS6620310SP	NUT 3/16-32				1.00
26	SS8120410SP	SCREW 3/16-28 L=3.8				1.00
27	TA0850604R0	RUBBER PLUG				1.00
28	11214608	FEED ROCKER BAR BUSHING				1.00
29	11214400	FEED ROCKER SHAFT				1.00
30	SS8150410TP	SCREW 15/64-28 L=4.0				1.00
31	11214756	HORIZONTAL BAR ASM.				1.00
32	11215118	ROLLER				2.00
33	RC0330415KP	SNAP RING				2.00
34	11215019	ROLLER SHAFT				1.00
35	RC0330415KP	SNAP RING				2.00
36	11214806	PIN				1.00
37	11214905	WALKING FOOT MOUNT				1.00
38	22881304	UPPER FEED PRESSER				1.00
39	SS6110610TP	SCREW 11/64-40 L=6				2.00
40	11214509	BUSHING				1.00
41	B3016450000A	PIN				1.00
42	SS6121220TP	SCREW 3/16-28 L=11.5				1.00
43	11214004	FEED ROCKER SHAFT CRANK, UPPER				1.00
44	11211000	ROCK SHAFT BUSHING, FRONT				1.00
45	CS120101BSH	THRUST COLLAR ASM.				2.00
46	SS8660410SP	SCREW 1/4-40 L=4.2		*		4.00
47	SS8120740SP	SCREW 3/16-28 L=7				1.00
48	SS6121220TP	SCREW 3/16-28 L=11.5				1.00
49	SS7090910TP	SCREW 9/64-40 L=8.5				1.00
50	11210705	WALKING FOOT ARM				1.00

51	11210804	WALKING FOOT ROCK SHAFT				1.00
52	11216801	DRIVING PRESSER ARM				1.00
53	SD0640451TP	HINGE SCREW D=6.35 H=4.5				1.00
54	11008703	WALKING FOOT LINK				4.00
55	22911002	WALKING FOOT PIN B				1.00
56	SS8120740SP	SCREW 3/16-28 L=7				2.00
57	22910905	WALKING FOOT PIN A				2.00
58	11210325	WALKING FOOT ADJUSTING LINK				1.00
59	SS4090815SP	SCREW 9/64-40 L=8				2.00
60	11210507	WALKING FOOT FULCRUM SHAFT A				1.00
61	11210408	WALKING FOOT ADJUSTING PIN				1.00
62	NS6620310SP	NUT 3/16-32				1.00
63	11210614	FULCRUM SHAFT B				1.00
64	11210903	ROCK SHAFT BUSHING, REAR				1.00
65	11216306	DRIVING ARM, REAR				1.00
66	SS6121220TP	SCREW 3/16-28 L=11.5				1.00
67	B412352200B	NEEDLE ROLLAR				1.00
68	11210051	LEVEL CAM ASM.				1.00
69	11210002	CAM		*		1.00
70	SS8660530TP	SCREW 1/4-40 L=4.5		*		2.00

TOP FEED MECHANISM & MOTOR COMPONENTS

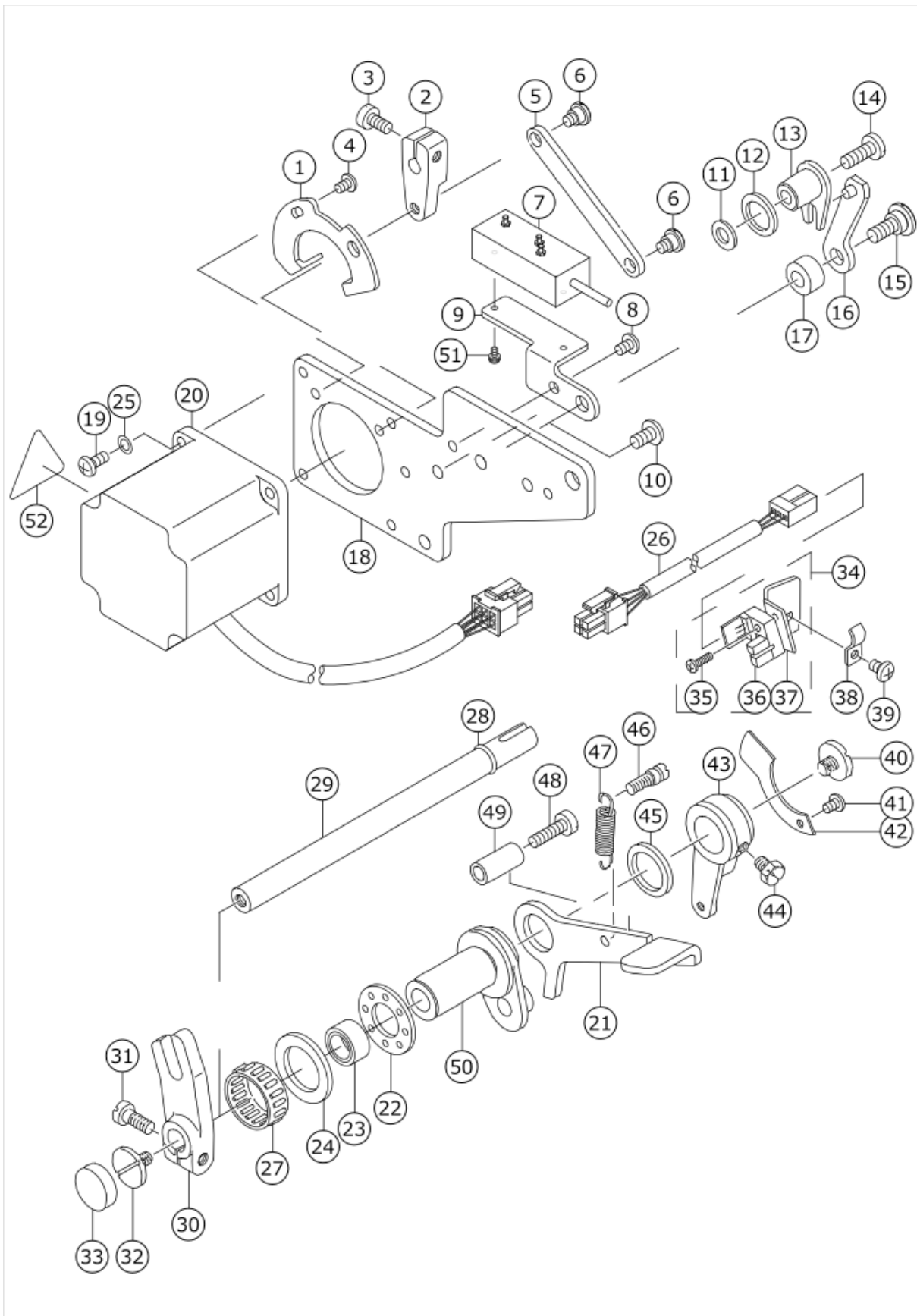

No.	品番	品名	備考	子部品	消耗品	個数
1	11274701	MOTOR ARM STOPPER				1.00
2	11274503	MOTOR ARM				1.00
3	SS6121010SP	SCREW 3/16-28 L=10				1.00
4	SS4110615SP	SCREW 11/64-40 L=6				2.00
5	11274602	MOTOR LINK				1.00
6	SD0640321SP	HINGE SCREW D=6.35 H=3.2				2.00
7	40034156	POTENTIOMETER ASM				1.00
8	SS4110615SP	SCREW 11/64-40 L=6				1.00
9	40032986	POTENTIOMETER BASE				1.00
10	SS4120915SP	SCREW 3/16-28 L=9				2.00
11	11273505	BRANCH SPACER				1.00
12	11273307	OIL SEAL				1.00
13	11273158	POTENTIOMETER CRANK ASM.				1.00
14	SS7121410SP	SCREW 3/16-28 L=14				1.00
15	SD0870401SP	HINGE SCREW D=8.73 H=4				1.00
16	11272952	POTENTIOMETER ARM ASM.				1.00
17	11273000	POTENTIOMETER ARM COLLAR				1.00
18	11274313	STEPPING MOTOR BASE				1.00
19	SS4110915TP	SCREW 11/64-40 L=9				4.00
20	11281458	STEPPING MOTOR				1.00
21	11280401	FEED CONTROL LEVER				1.00
22	B1211980000	UPPER SHAFT THRUST BEARING				1.00
23	B1641490000	OIL SEAL				1.00
24	B1242980000	THRUST WASHER, SMALL				1.00
25	WP0460556SD	WASHER 4.6X7.5X0.5				4.00
26	11281557	TRUNK CORD ASM.				1.00
27	B1644490000	NEEDLE BEARING				1.00
28	RO069180100	RUBBER RING				1.00
29	11274008	LEVER SHAFT				1.00
30	11211109	WALKING FOOT ADJUSTING ARM				1.00
31	SS6121250TP	SCREW 3/16-28 L=11.5				1.00
32	SS7620750SP	SCREW 3/16-32 L=6.5				1.00
33	TA1750502R0	RUBBER PLUG D=17.5 L=5				1.00
34	11274859	SENSOR ASM.				1.00
35	SL4031081SF	SCREW M3 L=10		*		1.00
36	HD000570000	SENSOR		*		1.00
37	11274800	SENSOR BASE		*		1.00
38	D2611555B00A	CABLE HOLDER				1.00
39	SS4110615SP	SCREW 11/64-40 L=6				1.00
40	SS7620750SP	SCREW 3/16-32 L=6.5				1.00
41	SS4110615SP	SCREW 11/64-40 L=6				1.00
42	11274206	SENSOR PLATE				1.00
43	11274107	UPPER FEED LEVER SHAFT ARM				1.00
44	SS9660910SP	SCREW 1/4-40 L=9.4				1.00
45	11272408	THRUST COLLAR				1.00
46	11272614	FEED SPRING HOOK				1.00
47	11272507	SPRING				1.00
48	SS6121840SP	SCREW 3/16-28 L=18				1.00
49	11100500	REVERSE FEED LEVER STOPPER				1.00
50	11272051	LEVER BASE ASM.				1.00

51	SL4020591SC	SCREW M2X5				2.00
52	CM300300003	HIGH TEMPARATURE CAUTION LABEL 2 (31.5)				1.00

THREAD TRIMMER COMPONENTS

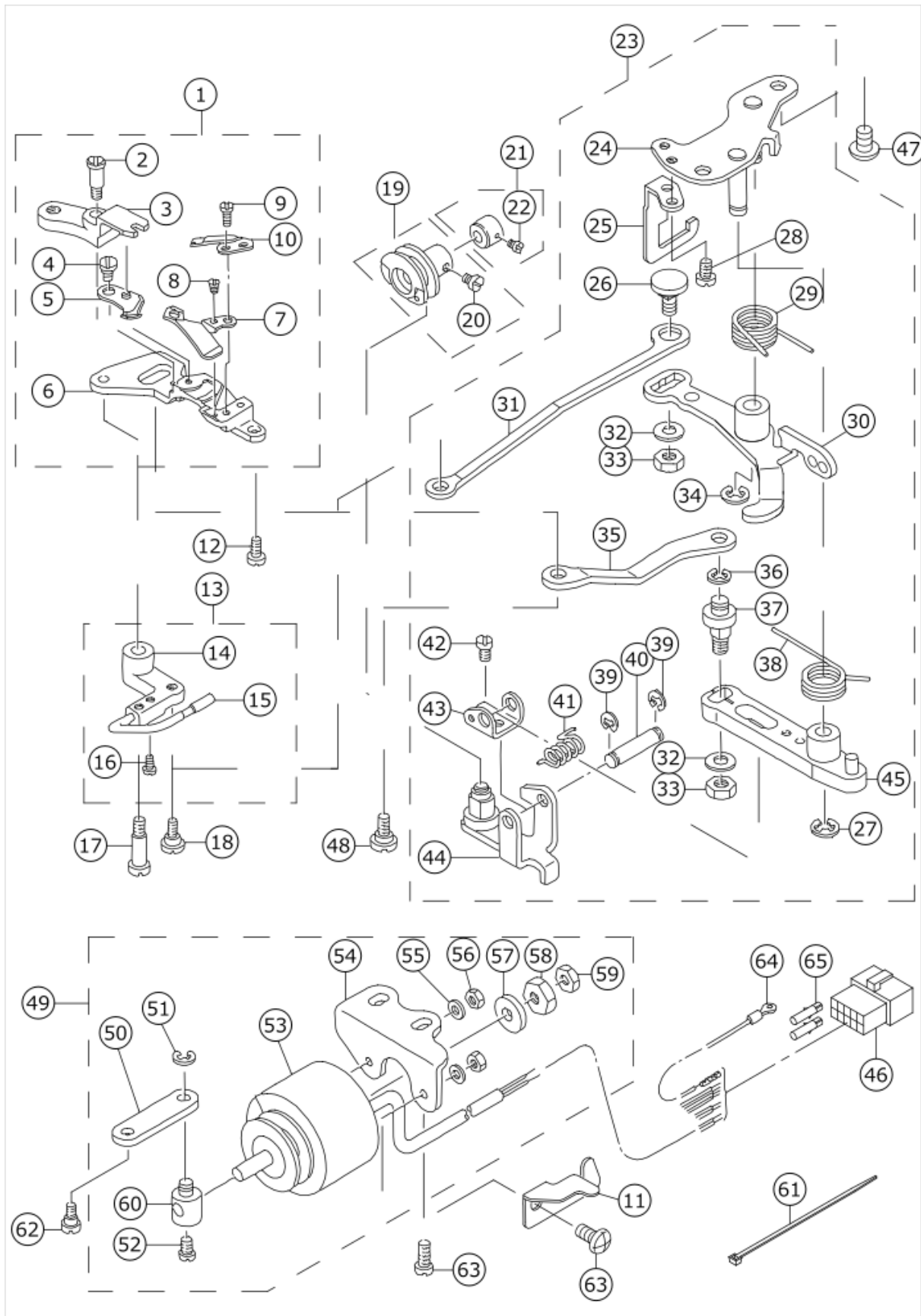

No.	品番	品名	備考	子部品	消耗品	個数
1	11232055	KNIFE UNIT				1.00
2	SD0460703TP	HINGE SCREW D=4.6 H=7		*		1.00
3	11232105	FORKED BASE FOR KNIFE		*		1.00
4	SD0500095TH	HINGE SCREW D=5 H=0.85		*		1.00
5	11040052	MOVING KNIFE ASM.		*		1.00
6	22947907	KNIFE MOUNTING BASE		*		1.00
7	11313103	THREAD GUIDE FOR KNIFE		*		1.00
8	SS2060210SP	SCREW 3/32-56 L=2.3		*		1.00
9	SS4080620TP	SCREW 1/8-44 L=6		*		2.00
10	D2406555D0H	COUNTER KNIFE		*		1.00
11	22962708	TUBE HOLDER, LOWER				1.00
12	SS4110715SP	SCREW 11/64-40 L=7				1.00
13	11042553	PICKER ARM ASM.				1.00
14	11042504	PICKER ARM		*		1.00
15	22950356	HOOK THREAD PRESSER ASM.		*		1.00
16	SS6090510SP	SCREW 9/64-40 L=5		*		2.00
17	SD0641451SP	HINGE SCREW D=6.35 H=14.5				1.00
18	SD0630275SP	HINGE SCREW D=6.35 H=2.7				1.00
19	11042850	THREAD TRIMMER CAM ASM.				1.00
20	SS6660610TP	SCREW 1/4-40 L=6		*		2.00
21	22950950	CAM COLLAR ASM.				1.00
22	SS8110520TP	SCREW 11/64-40 L=4.5		*		1.00
23	22949762	THREAD TRIMMER DRIVING UNIT				1.00
24	22949754	BASE PLATE ASM.		*		1.00
25	22950703	DRIVING ARM STOPPER		*		1.00
26	22950000	PICKER LINK PIN		*		1.00
27	RE0600000K0	E-RING 6		*		1.00
28	SS4110715SP	SCREW 11/64-40 L=7		*		2.00
29	22949408	CLUTCH SPRING		*		1.00
30	11041852	CLUTCH PLATE ASM.		*		1.00
31	22950109	PICKER LINK		*		1.00
32	WP0621016SH	WASHER		*		2.00
33	NS6150430SP	NUT 15/64-28		*		2.00
34	RE0600000K0	E-RING 6		*		1.00
35	22948301	MOVING KNIFE LINK		*		1.00
36	RE0500000K0	E-RING		*		1.00
37	22948400	MOVING KNIFE LINK PIN		*		1.00
38	22949309	KNIFE RETURN SPRING B		*		1.00
39	RE0400000K0	E-RING 4		*		2.00
40	22949101	ROLLER FULCRUM SHAFT		*		1.00
41	22949200	ROLLER RETURN SPRING		*		1.00
42	SS7090610SP	SCREW 9/64-40 L=6		*		1.00
43	22949002	ROLLER ARM SEAT		*		1.00
44	11040953	ROLLER ARM ASM.		*		1.00
45	11040854	KNIFE DRIVING ARM ASM.		*		1.00
46	HK034610140	HOUSING 14P				1.00
47	SS4150915SP	SCREW 15/64-28 L=9				2.00
48	SD0640631TP	HINGE SCREW D=6.35 H=6.3				1.00
49	11043957	SOLENOID UNIT				1.00
50	22949903	CLUTCH LINK		*		1.00

51	RE0500000K0	E-RING		*		1.00
52	SS6110710TP	SCREW 11/64-40 L=6.5		*		1.00
53	11043908	THREAD TRIMMER SOLENOID		*		1.00
54	22951404	SOLENOID BASE		*		1.00
55	WP0450000SD	WASHER 4.5X8X0.5		*		2.00
56	NM6040000SN	NUT M4		*		2.00
57	11043304	SOLENOID RUBBER		*		1.00
58	NS6660410SH	NUT		*		1.00
59	NS6660430SP	NUT 1/4-40		*		1.00
60	22951008	SOLENOID PIN		*		1.00
61	EA9500B0100	CABLE BAND				1.00
62	SD0600361SP	HINGE SCREW D=6 H=3.6				1.00
63	SS4151215SP	SCREW 15/64-28 L=12				3.00
64	11044054	GROUND WIRE ASM.				1.00
65	HK03464000B	PIN CONTACT				2.00

AUTOMATIC REVERSE FEED COMPONENTS

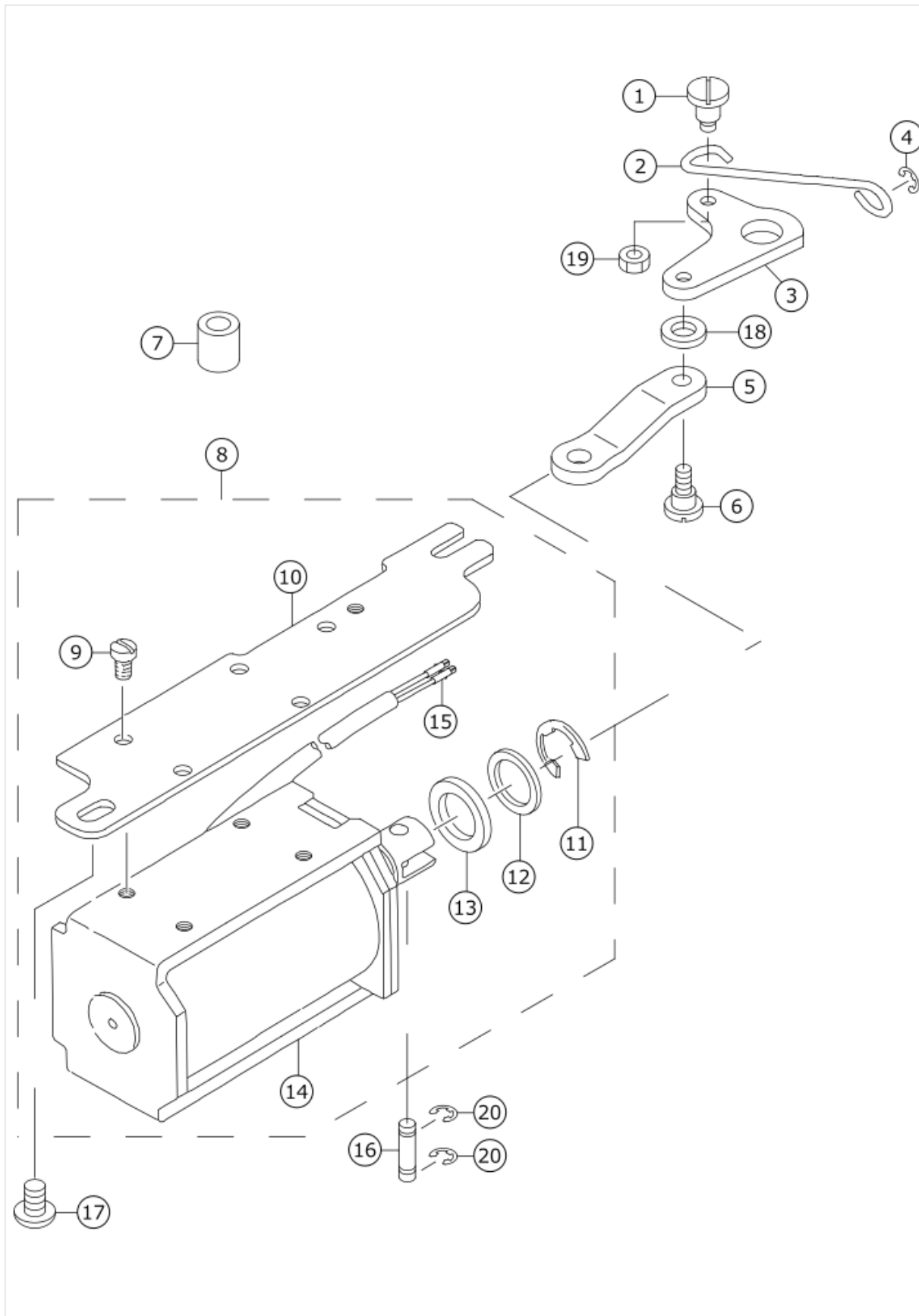

No.	品番	品名	備考	子部品	消耗品	個数
1	SD0700451TP	HINGE SCREW D=7 H=4.5				1.00
2	11101300	REVERSE FEED CONNECTING SHAFT				1.00
3	11101508	REVERSE FEED LINK				1.00
4	RE0500000KP	E-RING 5				1.00
5	22962500	SOLENOID CONNECTING LINK				1.00
6	SD0700711TP	HINGE SCREW D=7 H=7.1				1.00
7	22962609	REVERSE FEED BASE COLLAR				1.00
8	11228459	SOLENOID INSTALLING BASE ASM.				1.00
9	SS7110740TP	SCREW 11/64-40 L=7		*		4.00
10	11227600	SOLENOID INSTALLING PLATE		*		1.00
11	RE1200000K0	E-RING 12		*		1.00
12	WP1703001SC	WASHER 17X30X3		*		1.00
13	D2468555B00	RUBBER PLUNGER		*		1.00
14	11228400	REVERSE FEED SOLENOID		*		1.00
15	HK03464000B	PIN CONTACT		*		2.00
16	D2464555B00	LINK DRIVING MAGNET PIN				1.00
17	SS4150915SP	SCREW 15/64-28 L=9				1.00
18	WP0722316SH	WASHER				1.00
19	NS6110420SP	NUT 11/64-40				1.00
20	RE0400000K0	E-RING 4				2.00

OIL LUBRICATION COMPONENTS

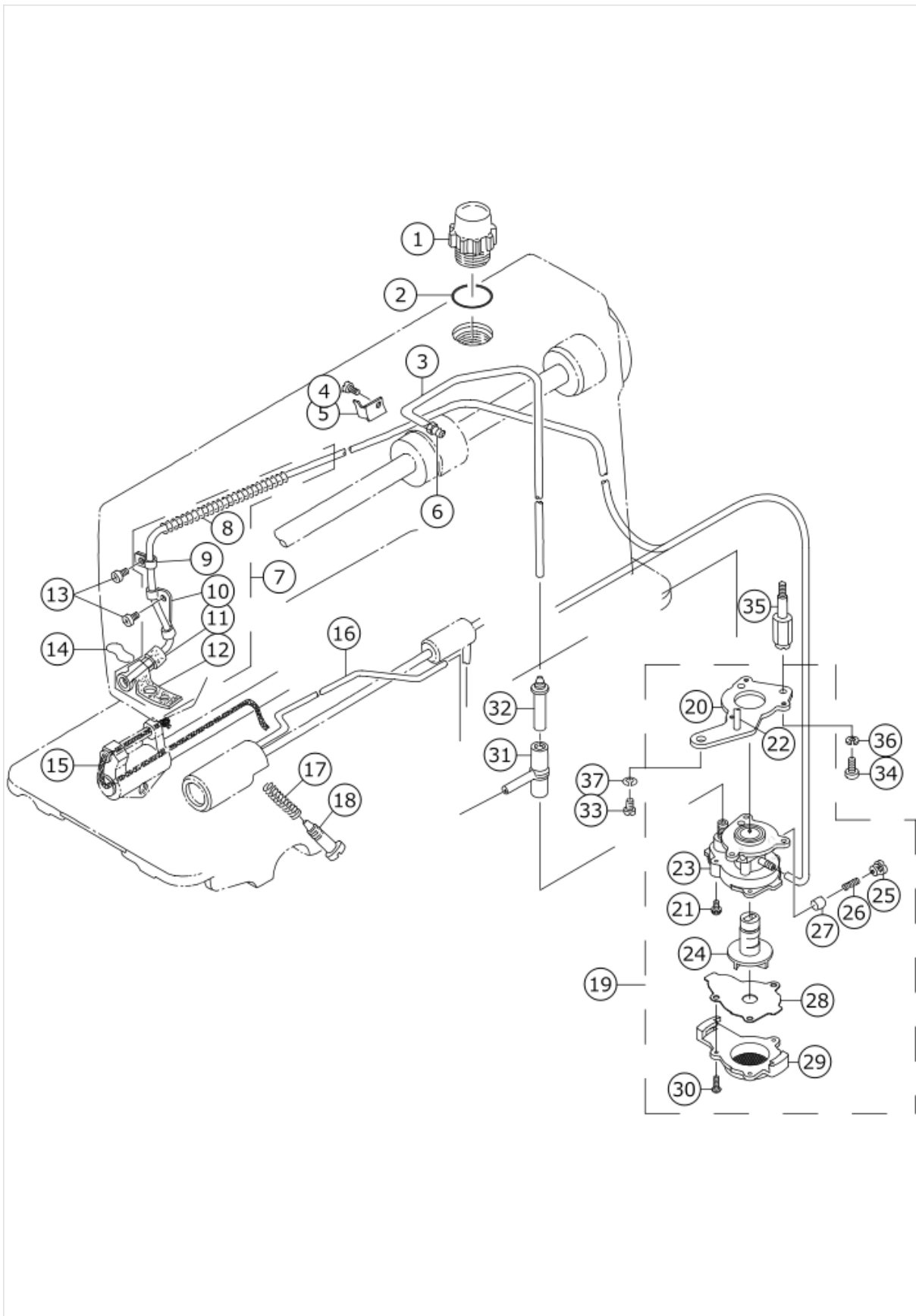

No.	品番	品名	備考	子部品	消耗品	個数
1	22947006	OIL SIGHT WINDOW				1.00
2	RO195240100	RUBBER RING				1.00
3	BT0600402EA	OIL TUBE				0.25
4	SS6080340SP	SCREW 1/8-44 L=2.9				1.00
5	11222007	HOLDER				1.00
6	SQ1150501SD	CONNECTING SCREW				1.00
7	11221652	OIL TUBE ASM.				1.00
8	B3404122000	SPRING		*		1.00
9	B3536122000	HOLDER		*		1.00
10	11221801	HOLDER A		*		1.00
11	11221702	FELT B		*		1.00
12	11221603	FELT A		*		1.00
13	SS4120615SP	SCREW 3/16-28 L=6				2.00
14	11221900	OIL FELT PRESSER				1.00
15	CQ252000000	OIL WICK				0.21
16	22924500	HOOK OIL TUBE				1.00
17	22924906	OIL REGULATOR SCREW SPRING				1.00
18	22925002	OIL REGULATOR SCREW				1.00
19	22923056	OIL PUMP ASM.				1.00
20	22923312	OIL PUMP INSTALLING BASE		*		1.00
21	SL4030851SF	SCREW M3 L=8		*		3.00
22	22923908	HOOK DRIVING SHAFT OILING PIPE		*		1.00
23	22923015	OIL PUMP		*		1.00
24	22923700	IMPELLER		*		1.00
25	22923502	PLUNGER SCREW		*		1.00
26	22923601	PLUNGER SPRING		*		1.00
27	22923403	PLUNGER		*		1.00
28	22923809	PUMP BODY SUPPORT PLATE		*		1.00
29	22923205	PUMP BODY COVER		*		1.00
30	SE4301041SR	SCREW D=3 L=10		*		3.00
31	22924609	RUBBER JOINT				1.00
32	11221504	OIL TUBE JOINT				1.00
33	SS4150915SP	SCREW 15/64-28 L=9				1.00
34	SS6111010TP	SCREW 11/64-40 L=9.5				1.00
35	11231503	OIL PUMP SUPPORT				1.00
36	WS0451040KP	SPRING WASHER 4.5X8.5X1				1.00
37	WS0651310KP	SPRING WASHER 6.5X11X1.3				1.00

MECHANISM & MISCELLANEOUS COVER COMPONENTS

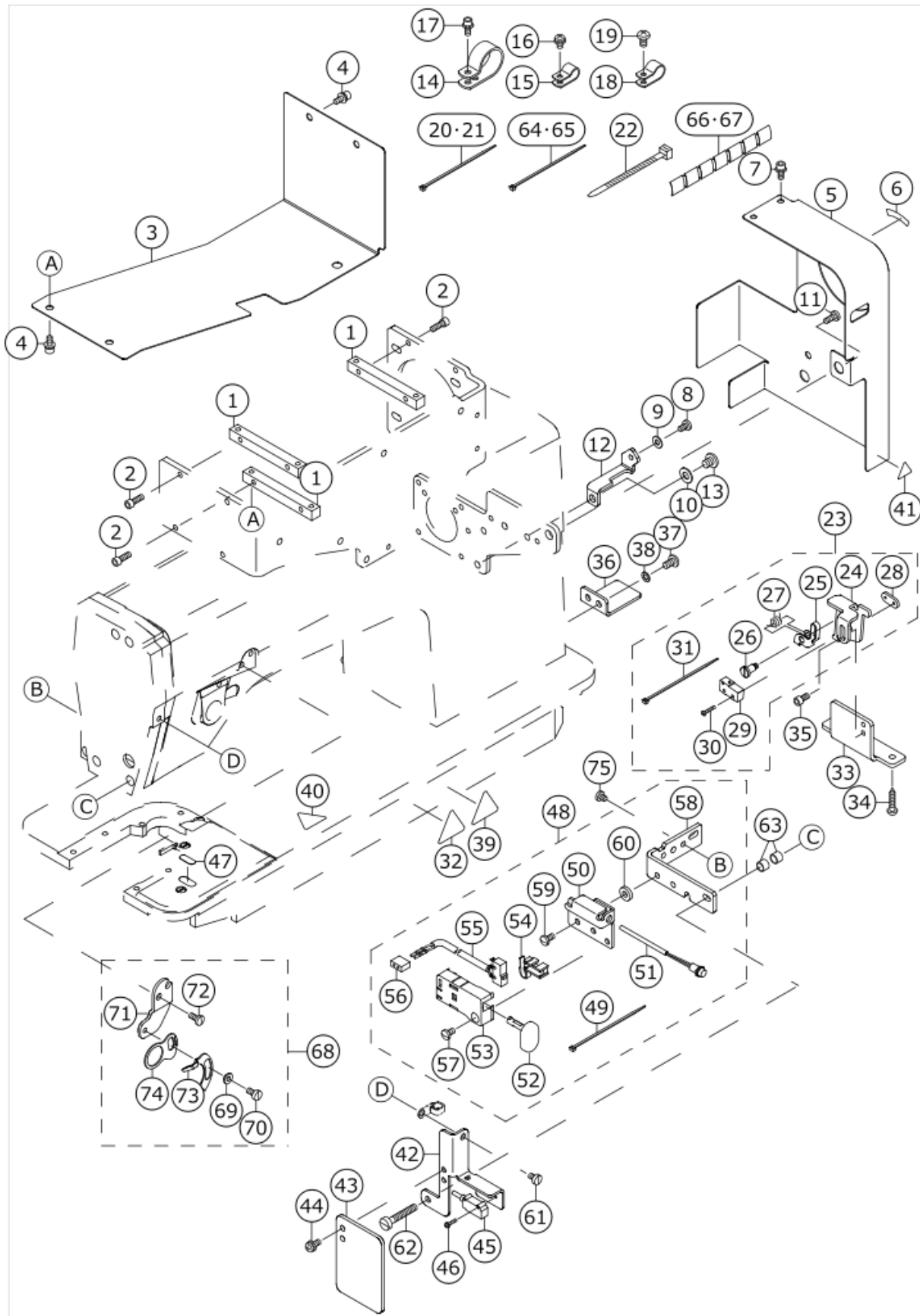

No.	品番	品名	備考	子部品	消耗品	個数
1	40088022	COVER_INSTALLING_PLATE				3.00
2	SM6041202TN	SCREW M4X0.7 L=12				6.00
3	40088023	MOTOR_COVER				1.00
4	SL6041092TN	SCREW				4.00
5	40088024	FLYING_WHEEL_COVER				1.00
6	B1144210000	REVOLVING_DIRECTION_LABEL				1.00
7	SL6041092TN	SCREW				2.00
8	SS7110710SP	SCREW 11/64-40 L=7				1.00
9	WP0450801SD	WASHER 4.5X10X0.8				1.00
10	WP0621016SD	WASHER 6.2X13X1				1.00
11	SS7701010SP	SCREW 5/16-24 L=10				1.00
12	11278306	BELT_COVER_STAY				1.00
13	SS4150715SP	SCREW 15/64-28 L=7				1.00
14	HX00150000M	CABLE_CLIP				1.00
15	HX00150000C	CABLE_CLIP				1.00
16	SL4040891SC	SCREW M4 L=8				1.00
17	SL6041092TN	SCREW				1.00
18	HX00150000D	CABLE_CLIP				1.00
19	SS4120915SP	SCREW 3/16-28 L=9				1.00
20	EA9500B0200	CABLE_BAND_150				10.00
21	EA9500B0200	CABLE_BAND_150				1.00
22	HX00065000A	CABLE_CLIP				3.00
23	40029776	SAFTY_SW_ASM.				1.00
24	40006496	SAFETY_SW_BASE		*		1.00
25	23638109	SAFETY_SWITCH_ARM		*		1.00
26	40006497	SAFETY_SW_ARM_SHAFT		*		1.00
27	23638208	SAFETY_SWITCH_SPRING		*		1.00
28	23638406	SAFETY_SWITCH_NUT		*		1.00
29	40029633	SAFETY_SW_CORD_ASM		*		1.00
30	SM4021201SC	SCREW M2 L=12		*		2.00
31	EA9500B0100	CABLE_BAND		*		1.00
32	CM300300003	HIGH_TEMPARATURE_CAUTION_LABEL_2(31.5)				1.00
33	40088026	SAFETY_SW_INSTALLING_PLATE				1.00
34	SK3412001SE	WOOD_SCREW D=4.1 L=20				2.00
35	SM6040802TP	SCREW M4X0.7 L=8				2.00
36	40088174	SW_SUPPRESSION_PLATE				1.00
37	SS4120915SP	SCREW 3/16-28 L=9				2.00
38	WP0480856SP	WASHER 4.8X8.4X0.8				2.00
39	CM300200003	FINGER_INJURY_CAUTION_LABEL(31.5)				1.00
40	CM300200002	CAUTION_LABEL(25)				1.00
41	CM300200001	ATTENTION_SEAL				1.00
42	40088019	SENSOR_PLATE				1.00
43	13889407	SAFETY_PLATE				1.00
44	SL4041081SC	SCREW M4 L=10				2.00
45	40084075	CLOTH_DETECTOR_ASSY				1.00
46	SL4021091SC	SCREW M2 L=10				2.00
47	40088020	CLOTH_DETECTION_REFLECTION_SHEET				1.00
48	40088207	SWITCH_ASM				1.00
49	EA9500B0100	CABLE_BAND		*		2.00
50	40088021	SWITCH_BASE		*		1.00

51	40041232	SW LED CABLE A ASSY		*		1.00
52	23631807	REVERSE FEED SWITCH SHAFT		*		1.00
53	23631708	REVERSE FEED SWITCH COVER		*		1.00
54	23631906	REVERSE FEED SWITCH SUPPORT		*		1.00
55	40018458	SW_CABLE_ASSY		*		1.00
56	HK016590060	HOUSING		*		1.00
57	SS7110740TP	SCREW 11/64-40 L=7		*		1.00
58	40088205	SWITCH_PLATE_DLU		*		1.00
59	SS7110840SP	SCREW 11/64-40 L=7.8		*		2.00
60	WP0502616SD	WASHER		*		2.00
61	SS6110610TP	SCREW 11/64-40 L=6				1.00
62	SS6123010SP	SCREW 3/16-28 L=30.0				1.00
63	22956809	WIPER COLLAR				2.00
64	EA9500B0100	CABLE BAND				10.00
65	EA9500B0100	CABLE BAND				2.00
66	HX00314000B	SPIRAL TUBE				1.00
67	HX00314000A	SPIRAL TUBE				1.50
68	40088632	THB_SENSOR_COMPONENTS	OPTIONAL PARTS			1.00
69	40028835	BUSHING		*		1.00
70	SM6040860TP	SCREW M4 L=8		*		1.00
71	40088029	SENSOR_PLATE_INSTALLING_PLATE		*		1.00
72	SS7110910TP	SCREW 11/64-40 L=8.5		*		2.00
73	40084061	THB SENSOR CORD ASSY		*		1.00
74	40028834	GUIDE_PLATE		*		1.00
75	SS7110510SP	SCREW 11/64-40 L=5				2.00

MAIN SEWING TABLE COMPONENTS

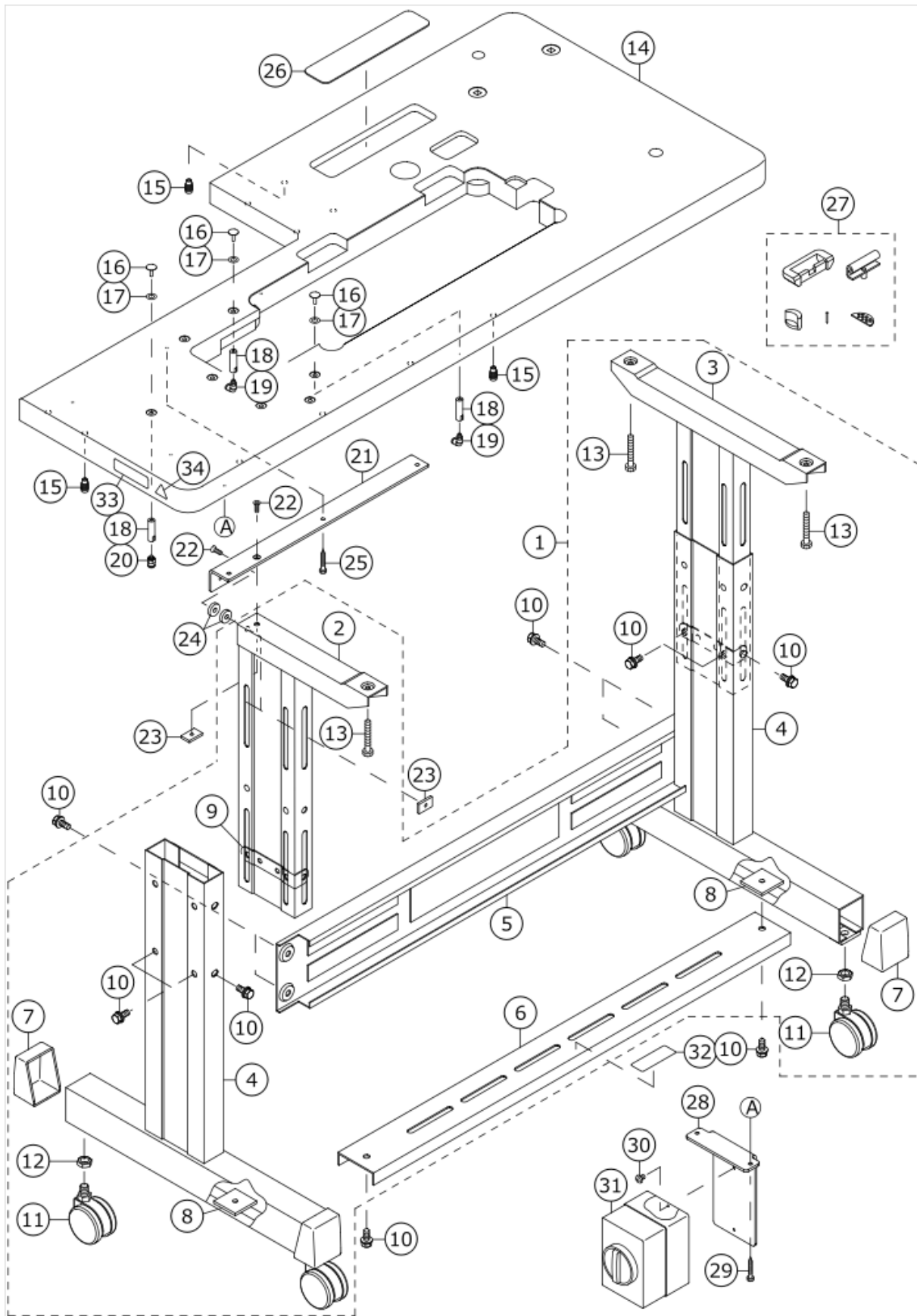

No.	品番	品名	備考	子部品	消耗品	個数
1	40088166	T-STAND_ASM.				1.00
2	40088167	UPPER_STAND_ASM.		*		1.00
3	40088172	UPPER_STAND_ASM.		*		1.00
4	B8105210AAA	STAND_ASM.		*		2.00
5	11158300	STAND_SIDE_SUPPORT		*		1.00
6	11158409	STAND_SIDE_SUPPORT		*		1.00
7	11158607	RUBBER_CAP		*		4.00
8	17007402	NUT		*		2.00
9	11158516	UPPER_STAND_PLATE		*		2.00
10	SL9082091SE	WASHER_HEXAGONAL_BOLT		*		12.00
11	B8150210000	CASTER		*		4.00
12	NM6120003SE	NUT_M12		*		4.00
13	ST9053511SR	TAPPING_SCREW_M5X35		*		3.00
14	40088168	TABLE				1.00
15	40075287	INSERT_NUT_M6X20				10.00
16	G5080397000	TABLE_BLOW				7.00
17	WP0550800SP	WASHER_5.5X10X0.8				7.00
18	40088169	STUD				7.00
19	PJ304060502	ELBOW_UNION_6XM5				6.00
20	PJ301060503	HALF_UNION				1.00
21	40088170	TABLE_BRACKET				1.00
22	SM1051601SC	SCREW_M5X0.8_L=16				2.00
23	18073403	NUT				2.00
24	17008004	WASHER				2.00
25	ST9053511SR	TAPPING_SCREW_M5X35				3.00
26	40088171	RUBBER_SHEET				1.00
27	22958052	RUBBER_HINGE_ASM.				1.00
28	40088182	SWITCH_BRACKET				1.00
29	ST9053511SR	TAPPING_SCREW_M5X35				2.00
30	SL4041081SC	SCREW_M4_L=10				2.00
31	HA005820000	SWITCH				1.00
32	16870206	GRAVITY_SEAL				1.00
33	40250687	COMPLETE_NAME_LABEL_AE200AN_V				1.00
34	40059020	BINDER_CAUTION_LABEL_S				1.00

BOBBIN WINDER UNIT

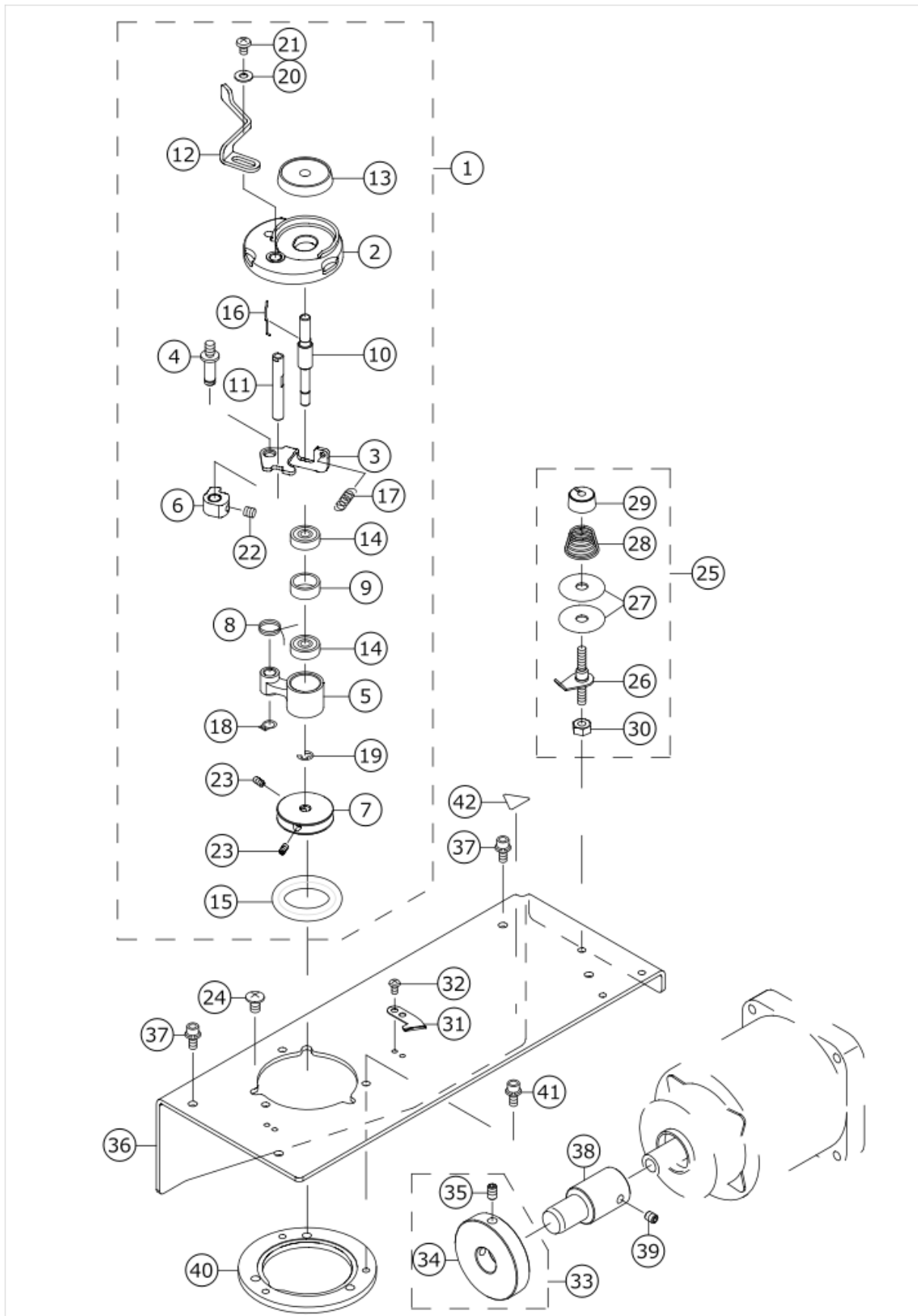

No.	品番	品名	備考	子部品	消耗品	個数
1	40011143	ASSY_BTW				1.00
2	26260109	BTW_BASE		*		1.00
3	26260208	BTW_CAM_PLATE		*		1.00
4	26260307	BTW_BASE_SHAFT		*		1.00
5	26260406	BTW_SHAFT_BASE		*		1.00
6	26260505	BTW_CAM_LEVER		*		1.00
7	26260604	BTW_WHEEL		*		1.00
8	40011144	BTW_TORSION_SPRING		*		1.00
9	26260802	BTW_BEARING_SPACER		*		1.00
10	40011145	BTW_SHAFT		*		1.00
11	40011146	BTW_LEVER_SHAFT		*		1.00
12	40021933	BTW_LEVER		*		1.00
13	26261206	BTW_SPACER		*		1.00
14	26261305	BTW_BEARING		*		2.00
15	26261503	BTW_WHEEL_RUBBER		*		1.00
16	26261602	BOBBIN_SPRING		*		1.00
17	26261701	BTW_SPRING		*		1.00
18	RC0560711KP	RETAINING RING		*		1.00
19	RE0400000K0	E-RING 4		*		1.00
20	WP0450826SC	WASHER 4.5X10X0.8		*		1.00
21	SM5040655SN	SCREW		*		1.00
22	SM8050502TP	SCREW M5 L=5		*		1.00
23	SM8040802TP	SCREW M4X8		*		2.00
24	SM0050801SC	SCREW				3.00
25	14113468	BOBBIN THREAD TENSION ASM.				1.00
26	14113450	BOBBIN THREAD TENSION ROD ASM.		*		1.00
27	B3126012000	THREAD TENSION DISK		*		2.00
28	D7133555B00	CONNECTING ROD SPRING		*		1.00
29	11072402	THREAD TENSION NUT		*		1.00
30	NS6110310SP	NUT 11/64-40		*		1.00
31	10502300	THREAD CUTTER				1.00
32	SM4030601SN	SCREW M3 X 6				2.00
33	40010533	BTW_DRIVING_WHEEL_ASM				1.00
34	40010534	BTW_DRIVING_WHEEL		*		1.00
35	40010535	DRIVING_WHEEL_SCREW		*		2.00
36	40088213	PRINT_CHART				1.00
37	SL6041092TN	SCREW				4.00
38	40088031	BOBBIN_WINDER_SHAFT				1.00
39	SM8050612TP	SCREW M5X6				2.00
40	40088032	BOBBIN_UNIT_PLATE				1.00
41	SL6041092TN	SCREW				3.00
42	CM300200001	ATTENTION SEAL				1.00

UPPER MANIPULATOR COMPONENTS

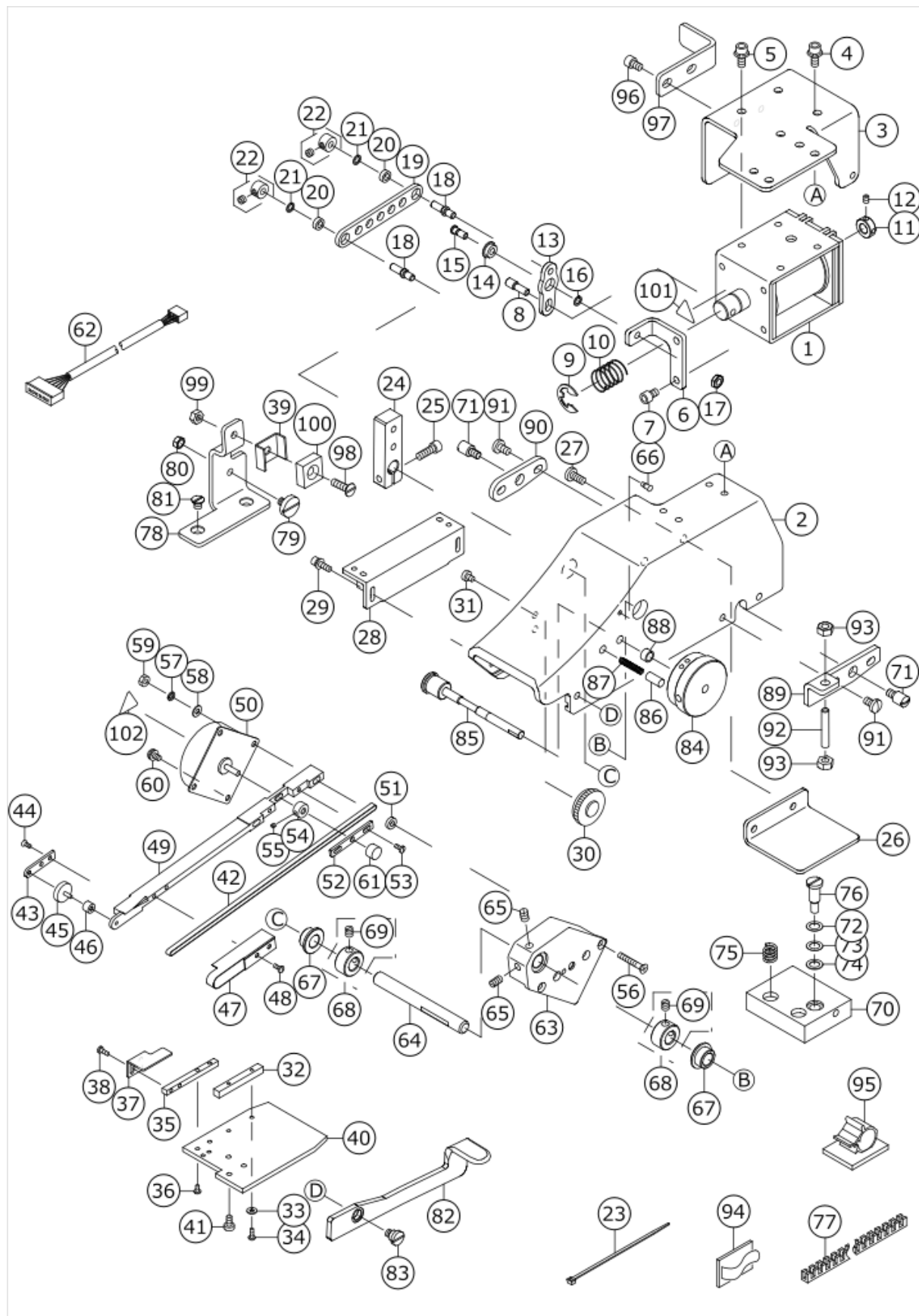

No.	品番	品名	備考	子部品	消耗品	個数
1	40084098	MANIPULATOR SOLENOID				1.00
2	40088147	UPPER_MANIPULATOR_COVER_B				1.00
3	40088148	UPPER_MANIPULATOR_SOLENOID_BASE				1.00
4	SL6041092TN	SCREW				4.00
5	SL6041092TN	SCREW				4.00
6	40088149	UPPER_MANIPULATOR_PIVOT_BASE				1.00
7	SM6040602TP	SCREW M4 L=6				2.00
8	40006617	AT_SOL_PIN				1.00
9	RE0900000K0	E-RING 9				1.00
10	40006625	SPRING				1.00
11	40010477	AT_SOL_COLLAR				1.00
12	SM8030412TP	SCREW				2.00
13	40088150	UPPER_MANIPULATOR_DRIVE_LINK_A				1.00
14	40010490	AT_PIVOT_BEARING				1.00
15	40010487	AT_PIVOT_SCREW				1.00
16	40010489	AT_PIVOT_SCREW_WASHER				2.00
17	NM6040003SC	NUT M4				1.00
18	40088151	BEARING_PIN				2.00
19	40088152	UPPER_MANIPULATOR_DRIVE_LINK_C				1.00
20	40010498	AT_JOINT_BEARING				2.00
21	40010489	AT_PIVOT_SCREW_WASHER				2.00
22	13172952	COLLAR ASM.				2.00
23	EA9500B0100	CABLE BAND				2.00
24	40088153	MANIPULATOR_DRIVE_LEVER				1.00
25	SM6041202TP	SCREW M4X0.7 L=12				1.00
26	40088154	COVER_MOUNTING_BASE				1.00
27	SS7110910TP	SCREW 11/64-40 L=8.5				2.00
28	18056408	SOLENOID				1.00
29	SL6031092TN	SCREW				2.00
30	18053355	GEAR ASM.				1.00
31	SS6080410SP	SCREW 1/8-44 L=4				2.00
32	18055103	RACK				1.00
33	WP0250516SD	WASHER 2.5X6X0.5				2.00
34	SM4020600SP	SCREW M2 L=6				2.00
35	18067108	SENSOR FIXER				1.00
36	SS5060410SP	SCREW 3/32-56 L=3.5				2.00
37	40096523	SENSOR_BRACKET				1.00
38	SS7060610SP	SCREW 3/32-56 L= 5.5				2.00
39	40098291	MAGNET_SAVER				1.00
40	18055202	SLIDER				1.00
41	SM6030600SP	SCREW M3X0.5 L=6				3.00
42	18059303	TIMING BELT				1.00
43	18065805	SUPPORT PLATE				1.00
44	SS2060510SP	SCREW 3/32-56 L=4.5				2.00
45	18054205	CONTROL ROLLER				1.00
46	18056804	SPROCKET A				1.00
47	18058909	ROLLER COVER				1.00
48	SS7060510SP	SCREW 3/32-56 L=4.8				2.00
49	18054700	SWING ARM				1.00
50	40084099	MANIPULATOR_MOTOR				1.00

51	18052902	SWING ARM COLLER				2.00
52	18054601	MOTOR FIXER				1.00
53	SS7060510SP	SCREW 3/32-56 L=4.8				2.00
54	18056903	SPROCKET B				1.00
55	SS8060210TP	SCREW				1.00
56	SM1032001SC	SCREW M3X0.5 L=20				2.00
57	WS0310702KS	SPRING WASHER				2.00
58	WP0320501SC	WASHER M3				2.00
59	NM6030001SC	NUT M3				2.00
60	SL4030681SC	SCREW M3 L=6				2.00
61	18052704	FELT				1.00
62	40084067	CLOTH EDGE SENSOR CORD 2 ASSY				1.00
63	40088157	MANIPULATOR MOUNTING BASE_B				1.00
64	40088146	UPPER_MANIPULATOR SHAFT				1.00
65	SS8110710SP	SCREW 11/64-40 L=6.5				2.00
66	B1161227000	RIVET				1.00
67	40088162	MANIPULATOR_SHAFT_METAL				2.00
68	CS080081CSH	THRUST COLLAR ASM. D=8.0 W=8				2.00
69	SS8110520TP	SCREW 11/64-40 L= 4.5		*		2.00
70	40088155	UPPER_MANIPULATOR_BASE				1.00
71	18055004	MANIPULATOR POSITIONING SHAFT				2.00
72	18069807	THRUST WASHER, A				1.00
73	18069203	THRUST WASHER, B				1.00
74	18069708	THRUST WASHER				1.00
75	18056101	SPRING				2.00
76	SD0641103TP	HINGE SCREW				1.00
77	HX00223000A	BUSHING				0.06
78	40096947	MAGNET_PLATE				1.00
79	SS6110630TP	SCREW 11/64-40 L=6				1.00
80	NS6110310SP	NUT 11/64-40				1.00
81	SS1110640TP	SCREW 11/64-40 L= 5.5				2.00
82	18055509	MANIPULATOR LEVER				1.00
83	SD0640321SP	HINGE SCREW D= 6.35 H= 3.2				1.00
84	18070854	SEAM ADJUST KNOB ASM.				1.00
85	18053603	SEAM ADJUST GEAR				1.00
86	18053801	RATCHET				1.00
87	18053900	SPRIG				1.00
88	18054403	COLLER				1.00
89	18071001	SHAFT RETAINER B				1.00
90	18059709	SHAFT RETAINER				1.00
91	SS7110710SP	SCREW 11/64-40 L=7				4.00
92	18071308	SENSOR STOPPER SHAFT				1.00
93	NS6110420SP	NUT 11/64-40				2.00
94	HX000930000	STAPLE, SMALL				1.00
95	E9608603000	STICKER (MIDDLE)				2.00
96	SM6040602TN	BOLT				2.00
97	40096948	MAGNET_CATCHER				1.00
98	SM1041400SP	SCREW				1.00
99	NM6040001SP	NUT M4X0.7				1.00
100	40096946	MAGNET				1.00
101	CM300300001	HIGH TEMPARATURE CAUTION LABEL 2 (16)				1.00

102	CM300300001	HIGH TEMPARATURE CAUTION LABEL 2 (16)				1.00
-----	-------------	---------------------------------------	--	--	--	------

LOWER MANIPULATOR COMPONENTS

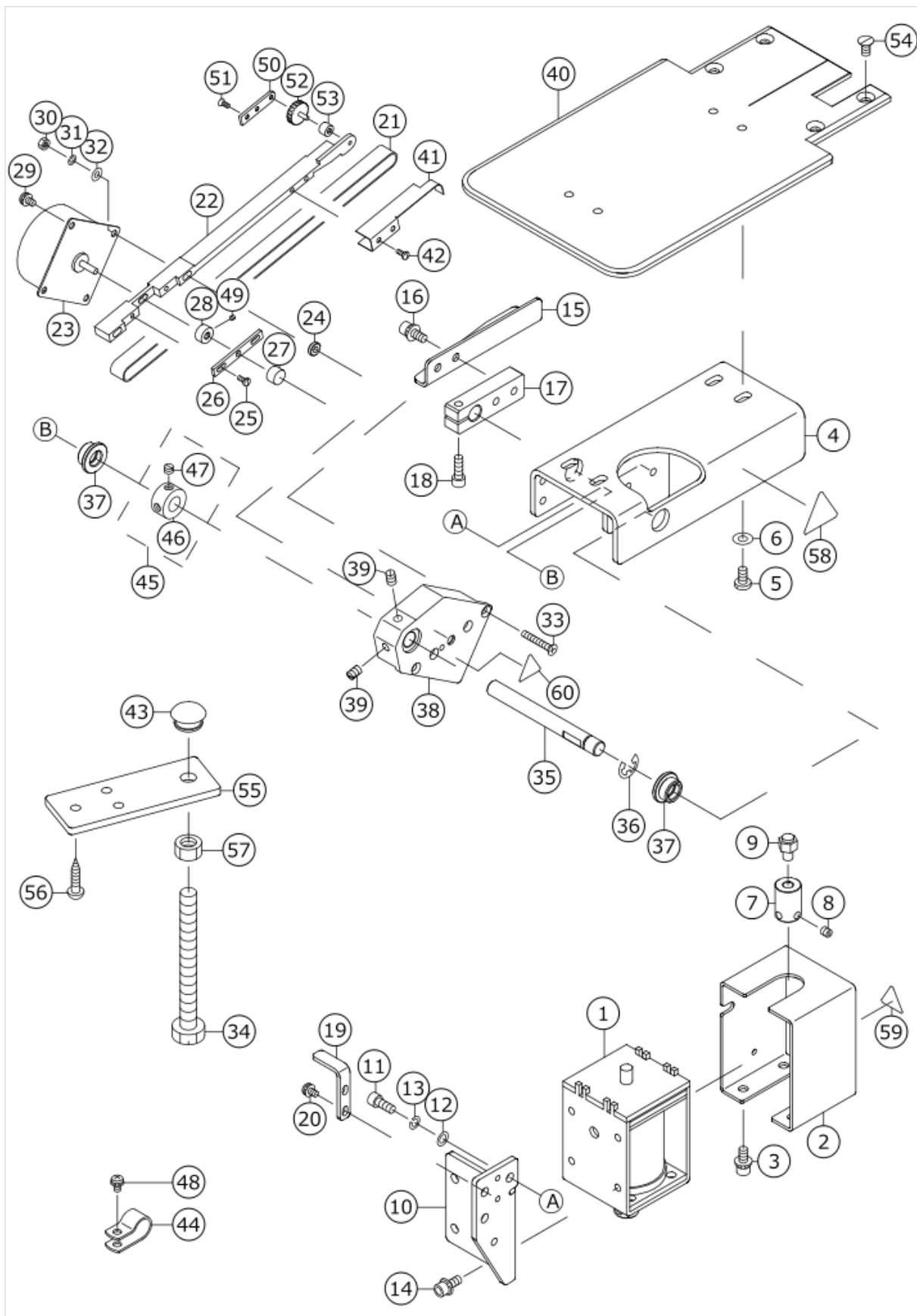

No.	品番	品名	備考	子部品	消耗品	個数
1	40084098	MANIPULATOR SOLENOID				1.00
2	40088163	LOWER_SOLENOID_COVER_B				1.00
3	SL6041092TN	SCREW				4.00
4	40088209	LOWER_MANIPULATOR_BASE				1.00
5	SS7110740TP	SCREW 11/64-40 L=7				4.00
6	WP0450801SD	WASHER 4.5X10X0.8				4.00
7	40088158	SOLENOID_STOPPER_B				1.00
8	SM8040412TP	SET SCREW M4 L=4				2.00
9	40088204	STOPPER_PIN				1.00
10	40088159	SOLENOID_BRACKET_B				1.00
11	SM6041002TP	SCREW M4 L=10				3.00
12	WP0450846SP	WASHER				3.00
13	WS0410002KP	SPRING WASHER				3.00
14	SL6041092TN	SCREW				4.00
15	40088160	LOWER MANIPULATOR_LEVER_B				1.00
16	SL6041092TN	SCREW				2.00
17	40088153	MANIPULATOR_DRIVE_LEVER				1.00
18	SM6041202TP	SCREW M4X0.7 L=12				1.00
19	40088164	LOWER_MANIPULATOR_LEVER_B_STOPPER				1.00
20	SL4030681SC	SCREW M3 L=6				2.00
21	18059303	TIMING BELT				1.00
22	18054700	SWING ARM				1.00
23	40084099	MANIPULATOR_MOTOR				1.00
24	18052902	SWING ARM COLLER				2.00
25	SS7060510SP	SCREW 3/32-56 L=4.8				2.00
26	18054601	MOTOR FIXER				1.00
27	18052704	FELT				1.00
28	18056903	SPROCKET B				1.00
29	SL4030681SC	SCREW M3 L=6				2.00
30	NM6030001SC	NUT M3				2.00
31	WS0310702KS	SPRING WASHER				2.00
32	WP0320501SC	WASHER M3				2.00
33	SM1032001SC	SCREW M3X0.5 L=20				2.00
34	SM9088013SE	SCREW M8 L=80				1.00
35	40088161	LOWER_MANIPULATOR_SHAFT				1.00
36	RE0600000K0	E-RING 6				1.00
37	40088162	MANIPULATOR_SHAFT_METAL				2.00
38	40088157	MANIPULATOR MOUNTING BASE_B				1.00
39	SS8110710SP	SCREW 11/64-40 L=6.5				2.00
40	40088165	LOWER MANIPULATOR BASE				1.00
41	40088221	LOWER CONTROL ROLLER COVER				1.00
42	SS7060510SP	SCREW 3/32-56 L=4.8				2.00
43	TA1250705R0	RUBBER PLUG				1.00
44	HX00150000D	CABLE CLIP				1.00
45	CS080081ASH	THRUST HOLDER ASM. D=8 W=8				1.00
46	CS0800816SH	THRUST HOLDER D=8 W=8		*		1.00
47	SS8110320SP	SCREW 11/64-40 L= 3.2		*		2.00
48	SL4030691SC	SCREW M3X6				1.00
49	SS8060210TP	SCREW				1.00
50	18065805	SUPPORT PLATE				1.00

51	SS2060510SP	SCREW 3/32-56 L=4.5				2.00
52	18054205	CONTROL ROLLER				1.00
53	18056804	SPROCKET A				1.00
54	SS1110840SP	SCREW 11/64-40 L=8				4.00
55	18059501	LOWER MANIPULATOR BASE				1.00
56	SK3412001SE	WOOD SCREW D=4.1 L=20				3.00
57	NM6080001SC	NUT M8X1.25				1.00
58	CM300200002	FINGER INJURY CAUTION LABEL (25)				1.00
59	CM300300003	HIGH TEMPARATURE CAUTION LABEL 2 (31.5)				1.00
60	CM300300001	HIGH TEMPARATURE CAUTION LABEL 2 (16)				1.00

AUTOMATIC PRESSER LIFTER COMPONENTS

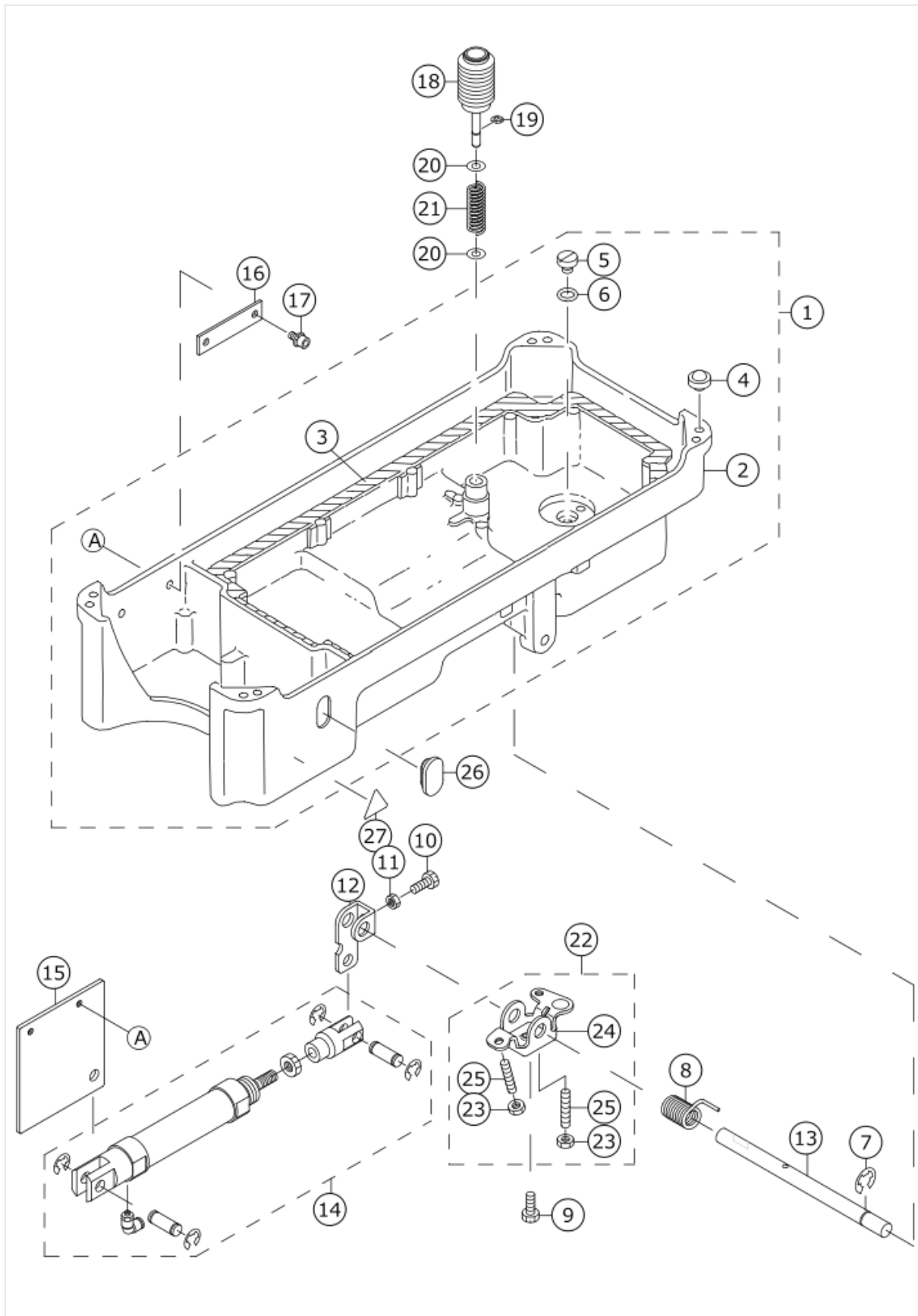

No.	品番	品名	備考	子部品	消耗品	個数
1	40088651	OIL PAN ASM				1.00
2	40088190	OIL PAN		*		1.00
3	11024700	GASKET		*		1.00
4	11047107	RUBBER CUSHION		*		4.00
5	SS6700710SH	SCREW 5/16-24 L=7		*		1.00
6	RO098240100	RUBBER RING		*		1.00
7	RE1000000K0	E-RING 10				1.00
8	22932206	SPRING				1.00
9	SM9061853SR	SCREW M6 L=17.5				1.00
10	SS9151540SR	SCREW 15/64-28 L=15				1.00
11	NS6150430SR	NUT 15/64-28				1.00
12	GAK53002000	LEVER				1.00
13	GAK39007000	KNEE PRESS ROD				1.00
14	PA2002510A0	AIR CYLINDER ASM.				1.00
15	GAK53001000	CYLINDER PLATE				1.00
16	GAK39005000	WASHER				1.00
17	SL6051092TN	BOLT				2.00
18	GAK300010B0	KNEE PRESS LIFTER ROD ASM.				1.00
19	RE0400000K0	E-RING 4				1.00
20	WP0621016SD	WASHER 6.2X13X1				2.00
21	GAK30005000	SPRING				1.00
22	22932156	KNEE LIFTER ROTATION ARM ASM.				1.00
23	NM6060001SE	NUT M6		*		2.00
24	22932107	KNEE LIFTING ROTATING ARM		*		1.00
25	SM8063012TR	SCREW M6 L=30		*		2.00
26	40028877	FACE_COVER_CAP				1.00
27	40059020	BINDER_CAUTION_LABEL_S				1.00

AIR COMPONENTS

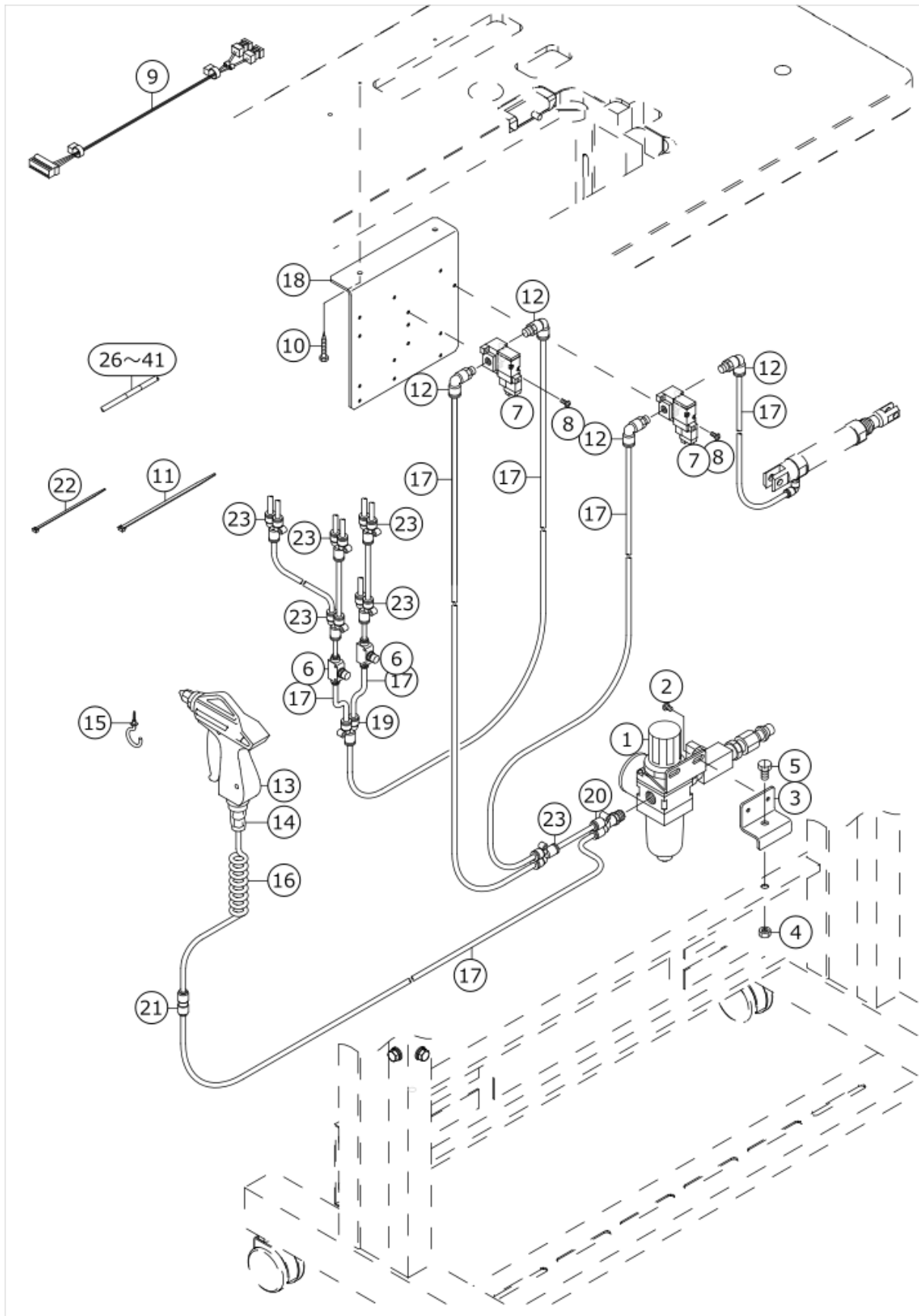

No.	品番	品名	備考	子部品	消耗品	個数
1	40088208	FILTER_REGULATOR_ASSY				1.00
2	SM4050801SC	SCREW M5X0.8 L=8				2.00
3	40023662	FILTER INSTALLING PLATE				1.00
4	NM6080721SE	NUT M8				1.00
5	SM9081620SE	SCREW M8 L=16				1.00
6	PC012601000	SPEED CONTROLLER				2.00
7	PV1351280A0	3-PORT SOLENOID VALVE				2.00
8	SM4041001SN	SCREW M4X0.7 L=10				4.00
9	40084066	VALVE CORD 1 ASSY				1.00
10	ST9053511SR	TAPPING SCREW M5X35				2.00
11	EA9500B0200	CABLE BAND 150				10.00
12	PJ304065101	ELBOW UNION 6XPT1/8				4.00
13	40044823	AIR_GUN				1.00
14	PJ301065201	HALF UNION 6XPT1/4				1.00
15	MAT81163T00	CORD HOLDER				1.00
16	GSS36020000	COIL TUBE				1.00
17	BT0600401EB	TUBE				10.00
18	40088188	VALVE_PANEL				1.00
19	PJ308060003	Y UNION				1.00
20	PJ308065202	Y-UNION				1.00
21	PJ303060001	STRAIGHT UNION				1.00
22	EA9500B0100	CABLE BAND				10.00
23	PJ308060004	Y UNION				6.00
24	18035006	CABLE MARK NO.1				2.00
25	18035105	WIRE MARK (2)				4.00
26	18035204	WIRE MARK (3)				4.00
27	18035303	WIRE MARK (4)				4.00
28	18035402	WIRE MARK (5)				4.00
29	18035501	WIRE MARK (6)				6.00
30	18035600	WIRE MARK (7)				4.00
31	18035709	WIRE MARK (8)				2.00
32	18035808	WIRE MARK (9)				2.00
33	18035907	WIRE MARK (10)				2.00
34	18036004	WIRE MARK (11)				4.00
35	18036103	WIRE MARK (12)				4.00
36	18036202	WIRE MARK (13)				4.00
37	18036301	WIRE MARK (14)				4.00
38	18036400	WIRE MARK (15)				4.00
39	18036509	WIRE MARK (16)				4.00
40	18036608	WIRE MARK (17)				4.00
41	18036707	WIRE MARK (18)				5.00

CONTROL BOX COMPONENTS

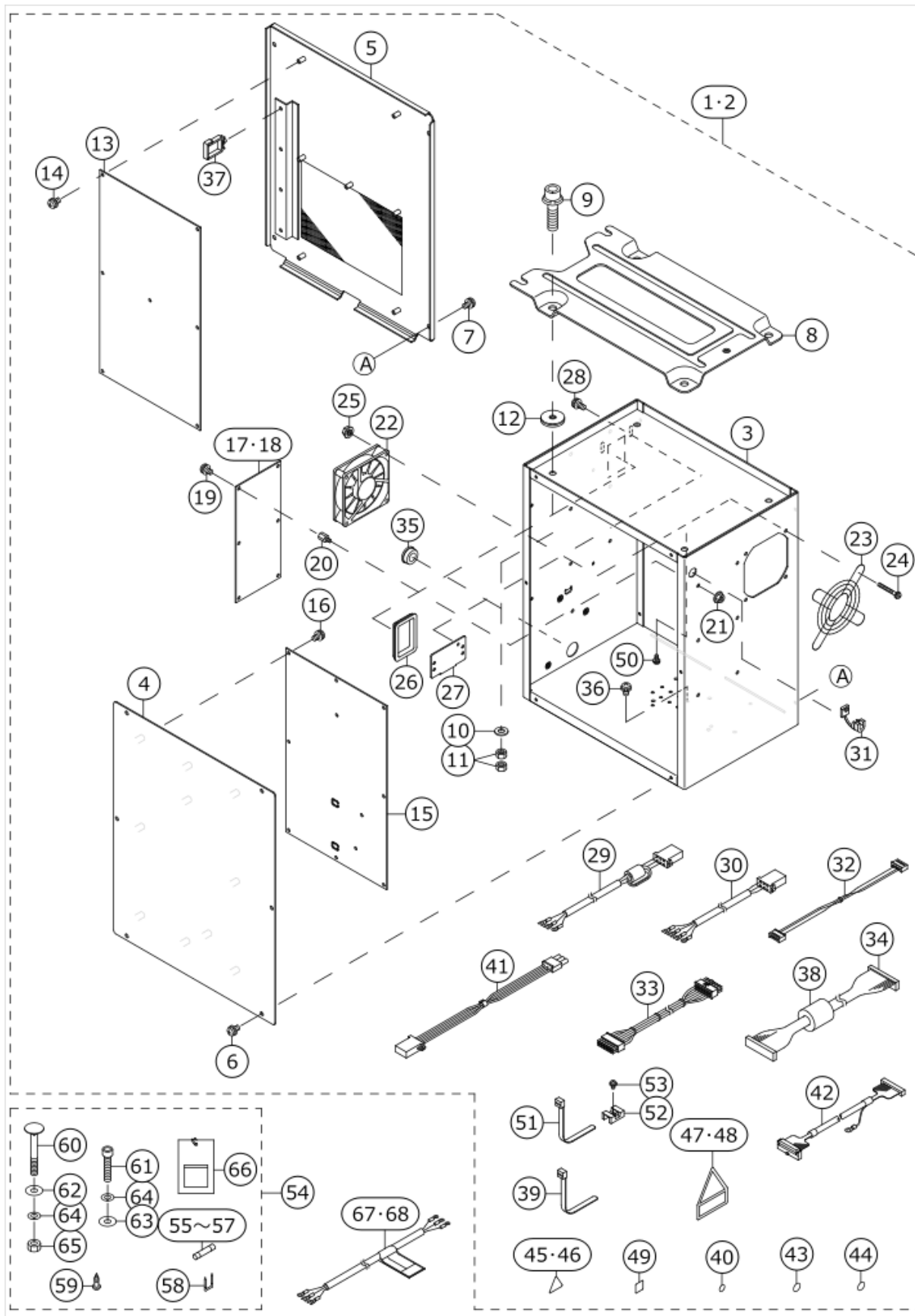

No.	品番	品名	備考	子部品	消耗品	個数
1	40251177	BOX A 1P	FOR 1-PHASE 220 ~ 240V			1.00
2	40251178	BOX B 3P	FOR 3-PHASE 200 ~ 220V USE IN JAPAN,EXPORT			1.00
3	40055355	CONTROL BOX		*		1.00
4	40094018	CONTROL BOX FRONT COVER		*		1.00
5	40094019	CONTROL BOX REAR COVER		*		1.00
6	SL4040891SC	SCREW M4 L=8		*		6.00
7	SL4040891SC	SCREW M4 L=8		*		4.00
8	M3801476000	CONTROL BOX FITTING PLATE		*		1.00
9	SL6083092TN	SCREW		*		4.00
10	WP0841601SC	WASHER 8.4X17.4X1.6		*		4.00
11	NM6080001SC	NUT M8X1.25		*		8.00
12	M4206461000	WASHER		*		4.00
13	40084041	MAIN PCB A ASSY		*		1.00
14	SL4040881SC	SCREW M4 L=8		*		7.00
15	40082758	SDC PCB A ASSY		*		1.00
16	SL4040881SC	SCREW M4 L=8		*		10.00
17	40000046	FLT-S PCB A ASS'Y	FOR 1-PHASE 220 ~ 240V	*		1.00
18	40000056	FLT-T PCB A ASS'Y	FOR 3-PHASE 200 ~ 220V USE IN JAPAN,EXPORT	*		1.00
19	SL4040881SC	SCREW M4 L=8		*		6.00
20	KX000000380	SPACER		*		6.00
21	NM3040520SC	NUT M4		*		6.00
22	40005401	FAN MOTOR ASS'Y		*		1.00
23	HM000480010	FINGER GUARD		*		1.00
24	SL4043591SC	SCREW		*		4.00
25	NM3040520SC	NUT M4		*		4.00
26	HX004070000	BUSH		*		1.00
27	17845009	CORD FITTING PLATE		*		1.00
28	SL4041091SC	SCREW M4 L=10		*		2.00
29	40091945	POWER CORD 1P ASSY	FOR 1-PHASE 220 ~ 240V	*		1.00
30	40084079	POWER CORD 3P ASSY	FOR 3-PHASE 200 ~ 220V USE IN JAPAN,EXPORT	*		1.00
31	HX00410000A	STRAIN RELIEF BUSHING		*		1.00
32	40005394	FLT-SDC CORD S ASS'Y		*		1.00
33	40005395	SDC-MAIN CORD P ASSY		*		1.00
34	40005727	SDC-MAIN CORD S ASSY		*		1.00
35	HX00326000K	CABLE BAND		*		1.00
36	SL4040891SC	SCREW M4 L=8		*		4.00
37	HX005110000	WIRE SADDLE		*		4.00
38	HN001490000	CORES				1.00
39	EA9500B0100	CABLE BAND				1.00
40	E9567319000	EARTH MARK		*		1.00
41	40005393	FLT-SDC CORD P ASS'Y		*		1.00

42	40065566	PANEL CABLE D ASM				1.00
43	40003458	MASK SEAL		*		15.00
44	CM200100001	PE MARK LABEL		*		1.00
45	CM300100003	VOLTAGE WARNING LABEL(25)	FOR 1-PHASE 220 ~ 240V	*		1.00
46	CM300100401	LABEL 3 (LARGE)	FOR 3-PHASE 20 0 ~ 220V USE IN JAPAN,EXPORT	*		1.00
47	CM300400601	VOLTAGE CAUTION LABEL	FOR 1-PHASE 220 ~ 240V	*		1.00
48	CM300400701	VOLTAGE CAUTION LABEL	FOR 3-PHASE 20 0 ~ 220V USE IN JAPAN,EXPORT	*		1.00
49	CM600100101	WEEE MARK LABEL S		*		1.00
50	SL4041081SC	SCREW M4 L=10	FOR 1-PHASE 220 ~ 240V	*		1.00
51	KX000000230	RELEASIBLE CABLE TIE				3.00
52	KX000000210	SADDLE TYPE TIE MOUNT				4.00
53	SL4040881SC	SCREW M4 L=8				4.00
54	40084058	OPTION A ASSY				1.00
55	HF00130315S	FUSE 3.15A 250V REF. NO.112		*		1.00
56	HF003000200	FUSE 2A (220/240V)		*		1.00
57	HF0013050P0	FUSE 5A		*		1.00
58	MAO11532000	CORD STAPLE		*		3.00
59	SK3512001SE	WOOD SCREW D=5.1 L=20		*		2.00
60	MTSHJ100003	BOLT		*		2.00
61	SM6084002TN	SCREW M8 L=40		*		1.00
62	WP0852086SC	WASHER M8		*		2.00
63	WP0841601SC	WASHER 8.4X17.4X1.6		*		1.00
64	WS0820002KR	SPRING WASHER, M8		*		3.00
65	NM6080002SC	NUT M8		*		2.00
66	M300451100A	VOLTAGE INDICATION CARD,A		*		1.00
67	40058397	AC POWER CORD B ASM	FOR 1-PHASE 220 ~ 240V			1.00
68	40058398	AC POWER CORD C ASM	FOR 3-PHASE 20 0 ~ 220V USE IN JAPAN,EXPORT			1.00

OPERATION PANEL COMPONENTS

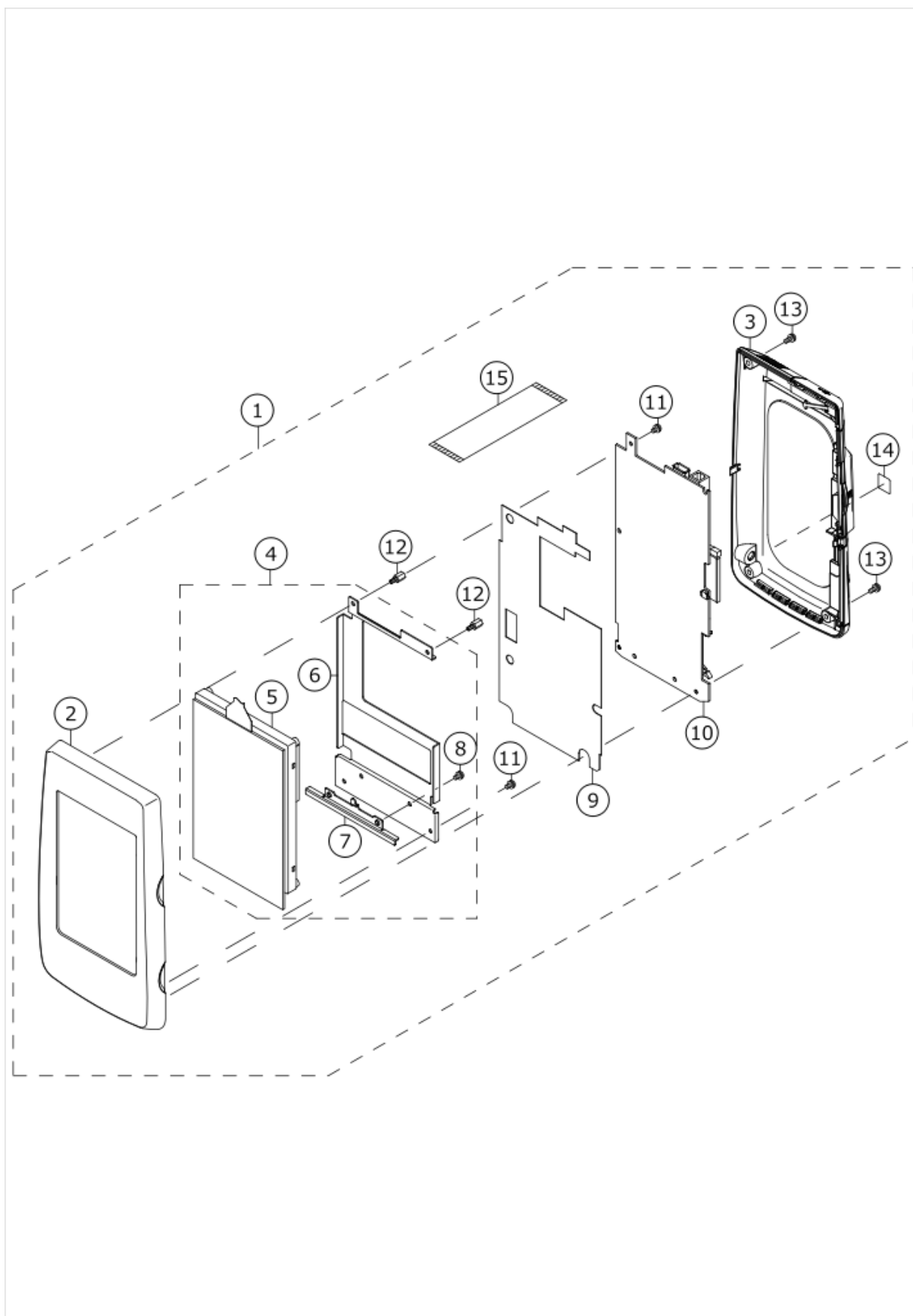

No.	品番	品名	備考	子部品	消耗品	個数
1	40251181	IP-420Z PANEL ASSY				1.00
2	40078163	FRONT_CASE		*		1.00
3	40080799	REAR_CASE_ASSY		*		1.00
4	40080800	LCD_ASSY		*		1.00
5	40086541	LCD TOUCH PANEL ASSY		*		1.00
6	40083668	LCD_BRACKET		*		1.00
7	40083666	LCD_STAY		*		1.00
8	SL4030681SC	SCREW M3 L=6		*		2.00
9	40078168	INSULATION_SHEET		*		1.00
10	40166481	PANEL PCB ASSY		*		1.00
11	SL4030681SC	SCREW M3 L=6		*		3.00
12	HX00354000B	PCB SUPPORT L=8MM		*		2.00
13	SL4030881SC	SCREW M3 L=8		*		4.00
14	CM600100101	WEEE MARK LABEL S		*		1.00
15	HW002650330	FLAT CABLE		*		1.00

WIRING DIAGRAM

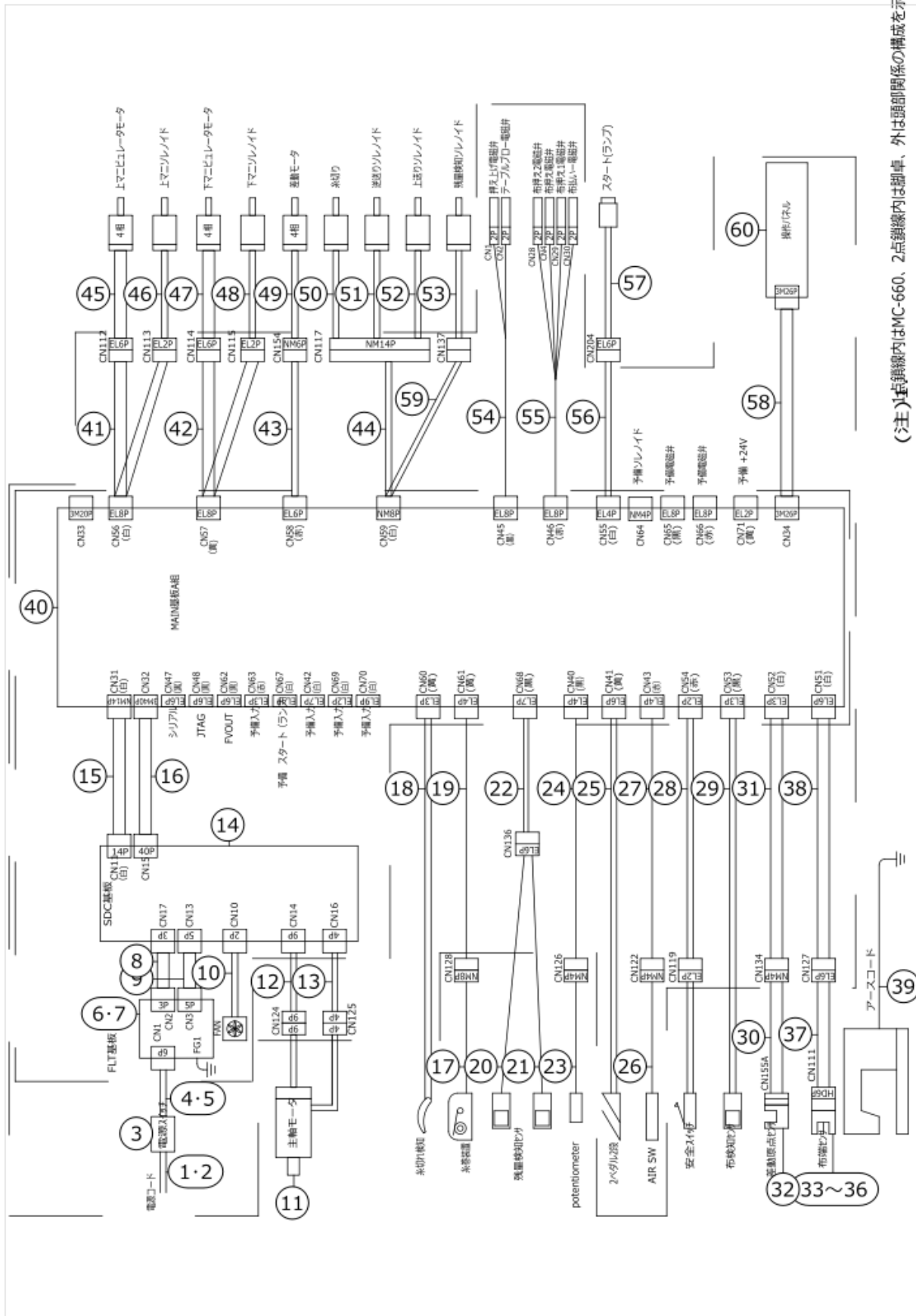

(注) 基幹線内はMC-660、2点鎖線内は副卓、外は頭部関係の構成を示す。

No.	品番	品名	備考	子部品	消耗品	個数
1	40058397	AC POWER CORD B ASM	FOR 1-PHASE 220 ~ 240V			1.00
2	40058398	AC POWER CORD C ASM	FOR 3-PHASE 20 0 ~ 220V USE IN JAPAN,EXPORT			1.00
3	HA005820000	SWITCH				1.00
4	40091945	POWER CORD 1P ASSY	FOR 1-PHASE 220 ~ 240V			1.00
5	40084079	POWER CORD 3P ASSY	FOR 3-PHASE 20 0 ~ 220V USE IN JAPAN,EXPORT			1.00
6	40000046	FLT-S PCB A ASS'Y	FOR 1-PHASE 220 ~ 240V			1.00
7	40000056	FLT-T PCB A ASS'Y	FOR 3-PHASE 20 0 ~ 220V USE IN JAPAN,EXPORT			1.00
8	40005393	FLT-SDC CORD P ASS'Y				1.00
9	40005394	FLT-SDC CORD S ASS'Y				1.00
10	40005401	FAN MOTOR ASS'Y				1.00
11	40050265	AC_SERVO_MOTOR				1.00
12	40084084	SERVO MOTOR ENCODER RELAY CORD				1.00
13	40084083	SERVO MOTOR RELAY CORD ASSY				1.00
14	40082758	SDC PCB A ASSY				1.00
15	40005395	SDC-MAIN CORD P ASSY				1.00
16	40005727	SDC-MAIN CORD S ASSY				1.00
17	40188446	BOBBIN_WINDER_ASSY				1.00
18	40084061	THB SENSOR CORD ASSY				1.00
19	40084086	BOBBIN WINDER CORD ASSY				1.00
20	40090488	PROXIMITY SENSOR ASSY				1.00
21	40090489	PROXIMITY SENSOR ASSY				1.00
22	40084059	LOWER THREAD SENSOR CORD ASSY				1.00
23	11281300	POTENTIOMETER				1.00
24	40084080	POTENTIOMETER CORD ASSY				1.00
25	40084064	PEDAL SWITCH ASM				1.00
26	40088208	FILTER_REGULATOR_ASSY				1.00
27	40084081	AIR SWITCH CORD ASSY				1.00
28	40084074	SAFETY SW CORD ASSY				1.00
29	40084075	CLOTH DETECTOR ASSY				1.00
30	11281557	TRUNK CORD ASM.				1.00
31	40084076	DIFFERENTIAL POSITION CORD ASSY				1.00
32	HD000570000	SENSOR				1.00
33	40084100	EDGE SENSOR 4/2	TYPE 4/2			1.00
34	40084101	EDGE SENSOR 4/4	TYPE 4/4			1.00
35	40084102	EDGE SENSOR 2/2	TYPE 2/2			1.00
36	40084103	EDGE SENSOR 4/2-3	TYPE 4/2-3			1.00
37	40084067	CLOTH EDGE SENSOR CORD 2 ASSY				1.00
38	40084085	CLOTH EDGE SENSOR CORD 1 ASSY				1.00
39	40090869	EARTH CORD ASSY				1.00
40	40084041	MAIN PCB A ASSY				1.00
41	40084070	UPPER_MANI CORD ASSY				1.00

42	40084069	LOWER_MANI CORD ASSY				1.00
43	40084077	DIFFERENTIAL MOTOR CORD ASSY				1.00
44	40084071	SOLENOID CORD ASSY				1.00
45	40084099	MANIPULATOR_MOTOR				1.00
46	40084098	MANIPULATOR SOLENOID				1.00
47	40084099	MANIPULATOR_MOTOR				1.00
48	40084098	MANIPULATOR SOLENOID				1.00
49	11281458	STEPPING MOTOR				1.00
50	11043908	THREAD TRIMMER SOLENOID				1.00
51	11228459	SOLENOID INSTALLING BASE ASM.				1.00
52	11281656	SOLENOID ASM.				1.00
53	40084091	ROTARY SOLENOID ASSY				1.00
54	40084066	VALVE CORD 1 ASSY				1.00
55	40084082	VALVE CORD 2 ASSY				1.00
56	40084073	START SWITCH CORD ASSY				1.00
57	40014098	OPTION_SWITCH_ASSY				1.00
58	40065566	PANEL CABLE D ASM				1.00
59	40091087	SOLENOID EXTENSION CORD ASSY				1.00
60	40251181	IP-420Z PANEL ASSY				1.00

ACCESSORIE PART COMPONENTS

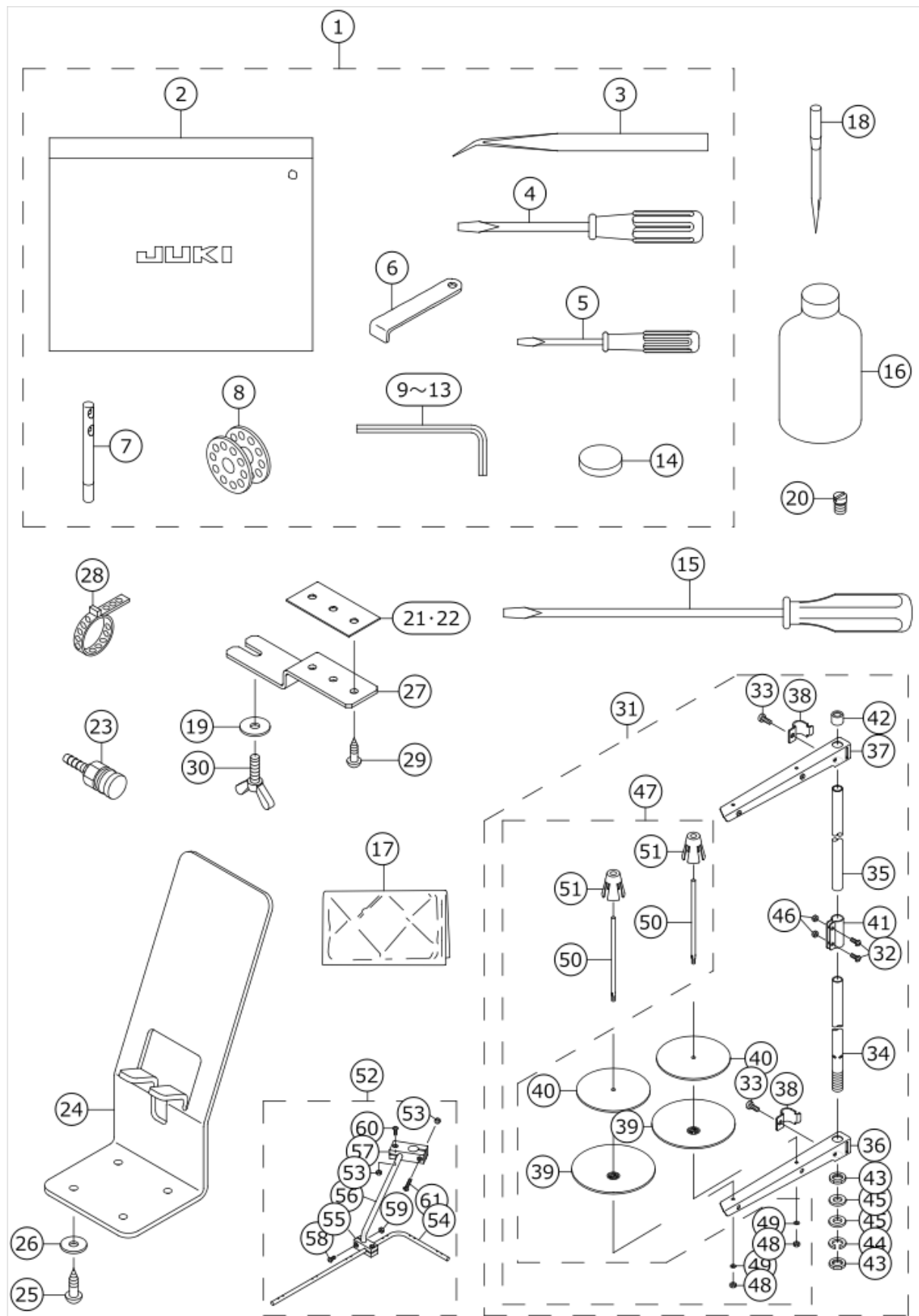

No.	品番	品名	備考	子部品	消耗品	個数
1	40088641	ACCESSORIES BAG ASM				1.00
2	22932800	ACCESSORIE BAG		*		1.00
3	12288403	TWEEZERS		*		1.00
4	22933105	SCREW DRIVER,MIDDLE		*		1.00
5	22933204	SCREW DRIVER,SMALL		*		1.00
6	B9101490000	DRIVER		*		1.00
7	22958300	NEEDLE THREAD GUIDE PIN		*		1.00
8	22932909	BOBBIN		*		1.00
9	GCT02906000	HEXAGONAL SPANNER		*		1.00
10	B9140372000	HEXAGONAL WRENCH, SMALL		*		1.00
11	B9141372000	HEXAGONAL WRENCH, LARGE		*		1.00
12	12455705	HEXAGONAL WRENCH, 2.5		*		1.00
13	J106600000B	HEXAGONAL WRENCH KEY (2MM)		*		1.00
14	B8228125000	OIL RESERVOIR MAGNET		*		1.00
15	22933006	SCREW DRIVER,LARGE				1.00
16	MDFRX1600C0	DEFRIX OIL NO.1(600CC)				1.00
17	22933303	VINYL COVER				1.00
18	MDB100B1102	NEEDLE DBX1#11-2				1.00
19	WP0651646SC	WASHER				2.00
20	B1191490000	SCREW				1.00
21	16193203	SPACER				1.00
22	16193005	SPACER				2.00
23	PJ309520001	SOCKET				1.00
24	40088189	PANEL_PLATE				1.00
25	SK3512001SE	WOOD SCREW D=5.1 L=20				4.00
26	WP0561616SC	WASHER 5.6X16X1.6				4.00
27	40088184	INSTALLING_PLATE				2.00
28	PB000010000	HOSE BAND				1.00
29	SK3451601SE	WOOD SCREW D=4.5 L=16				6.00
30	16187007	WING BOLT				2.00
31	22930358	THREAD STAND ASM.				1.00
32	SM4051405SE	SCREW M5 L=14		*		2.00
33	SM6061610SC	SCREW M6 L=16		*		2.00
34	22930309	SPOOL REST ROD, LOWER		*		1.00
35	22930408	SPOOL REST ROD, UPPER		*		1.00
36	22930507	SPOOL REST ARM		*		1.00
37	22930556	THREAD STANDING ARM ASM.		*		1.00
38	22930705	THREAD GUIDE ARM JOINT		*		2.00
39	22930804	SPOOL REST		*		2.00
40	22930903	SPOOL REST CUSHION		*		2.00
41	22931307	SPOOL REST ROD JOINT		*		1.00
42	22931406	SPOOL REST ROD RUBBER CAP		*		1.00
43	NM6160511SE	NUT M16X1.5		*		2.00
44	WS1643202KR	SPRING WASHER		*		1.00
45	WP1612616SE	WASHER 16X30X2.6		*		2.00
46	NM6050001SE	NUT M5		*		2.00
47	40062684	SPOOL PIN ASM.		*		1.00
48	NM6050001SE	NUT M5		*		2.00
49	WS0510002KN	SPRING WASHER		*		2.00
50	22931000	SPOOL PIN		*		2.00

51	22931109	SPOOL RETAINER		*		2.00
52	26910059	THREAD GUIDE ARM ASM.				1.00
53	NM6040002SE	NUT M4X0.7		*		2.00
54	13167903	THREAD STANDING THREAD GUIDE		*		1.00
55	13168000	THREAD GUIDE BASE, LOWER		*		1.00
56	13168109	THREAD GUIDE ARM BASE		*		1.00
57	13168208	THREAD GUIDE ARM BASE		*		1.00
58	SM4041001SC	SCREW M4X0.7 L=10		*		2.00
59	NM6040002SE	NUT M4X0.7		*		2.00
60	SM4041201SC	SCREW M4 L=12		*		1.00
61	SM4042001SC	SCREW M4 X 20		*		1.00

PIN TUCK COMPONENTS

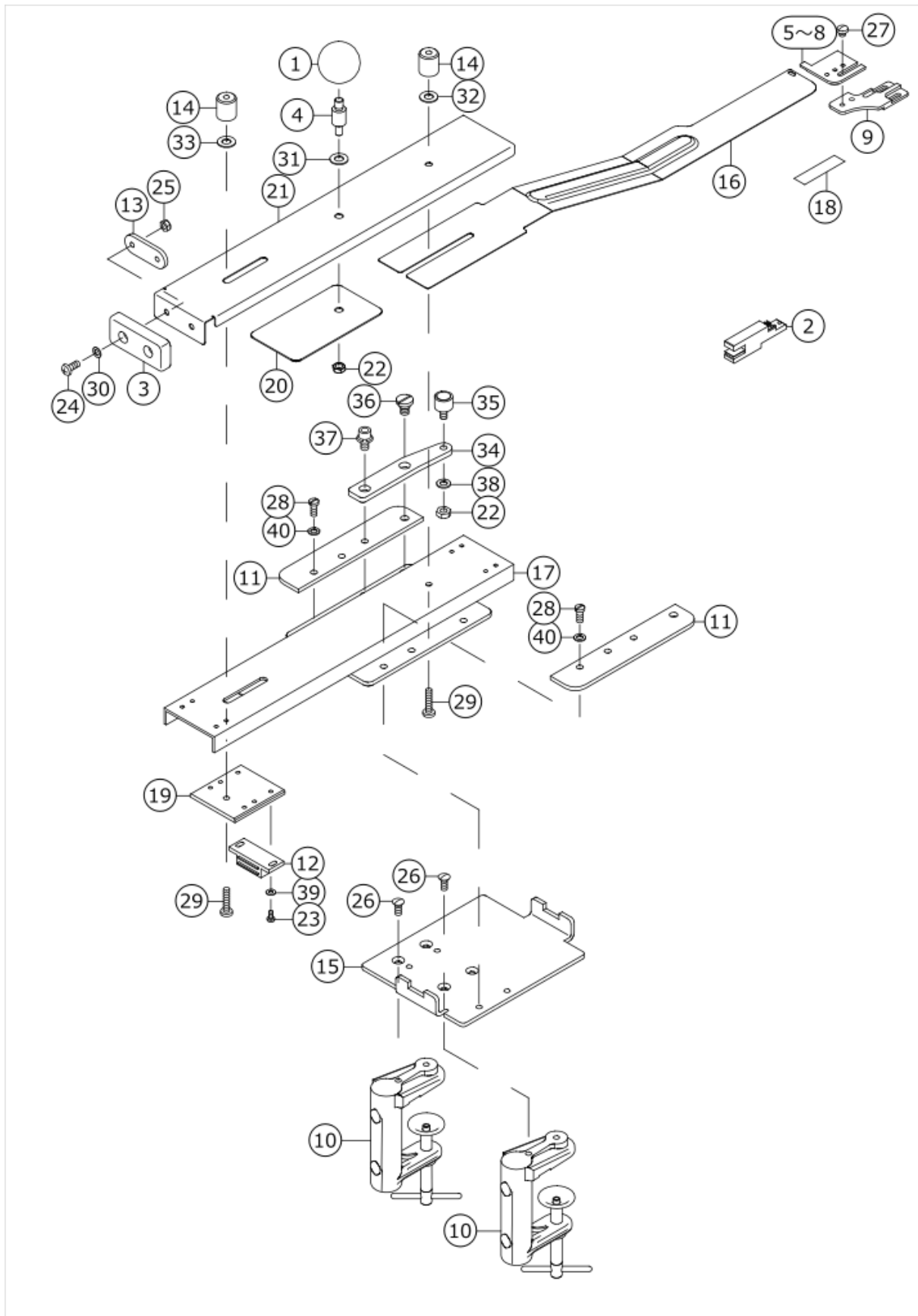

No.	品番	品名	備考	子部品	消耗品	個数
1	B1564777000	PRESSER LATCH LEVER BLOCK				1.00
2	40084103	EDGE SENSOR 4/2-3				1.00
3	GET04102000	RUBBER CAP				1.00
4	MAS05507000	HINGE STUD				1.00
5	40088194	TUCK_GAUGE_S				1.00
6	40088195	TUCK_GAUGE_A				1.00
7	40088196	TUCK_GAUGE_B				1.00
8	40088197	TUCK_GAUGE_C				1.00
9	40088198	GUIDE_BASE_PLATE				1.00
10	MAS059010A0	MOUNTING BASE ASM.				2.00
11	40088199	SLIDE_RAIL_COVER				2.00
12	MAS05905000	MAGNET				1.00
13	MAS05910000	CAP SUPPORT PLATE				1.00
14	MAS05926000	KNOB				2.00
15	40088200	PIN-TUCK STOPPER				1.00
16	40088216	GAUGE PLATE				1.00
17	40088201	SLIDE_RAIL				1.00
18	MAS15505000	SCALE PLATE				2.00
19	40088175	MAGNET_INSTALLING_PLATE				1.00
20	MAS15507000	LINER				1.00
21	40088202	PIN_TUCK_COVER				1.00
22	NM6050003SC	NUT M5X0.8				1.00
23	SM4030601SN	SCREW M3 X 6				2.00
24	SM4041055SP	SCREW				2.00
25	NM6040001SP	NUT M4X0.7				2.00
26	SS2111010TP	SCREW 11/64-40 L=9.5				4.00
27	SS5090420SP	SCREW 9/64-40 L=3.5				2.00
28	SS7111120TP	SCREW				4.00
29	SS7111810TP	SCREW 11/64-40 L=18				2.00
30	WP0450000SD	WASHER 4.5X8X0.5				2.00
31	WP0612066SP	WASHER 6.1X11X2				1.00
32	WP0612516SD	WASHER 6.1X15.2X2.5				1.00
33	WP0650876SD	WASHER 6.5X13X0.8				1.00
34	40088203	CAM_FOLLOWER_INSTALLING_PLATE				1.00
35	40027870	CAM FOLLOWER				1.00
36	SD0800337TP	SHOULDER SCREW				1.00
37	SL6051092TN	BOLT				1.00
38	WP0531000SC	WASHER 5.3X10X1				1.00
39	WP0320501SC	WASHER M3				2.00
40	WP0480856SP	WASHER 4.8X8.4X0.8				4.00

BOBBIN THREAD REMAINING AMOUNT DETECTING COMPONENTS

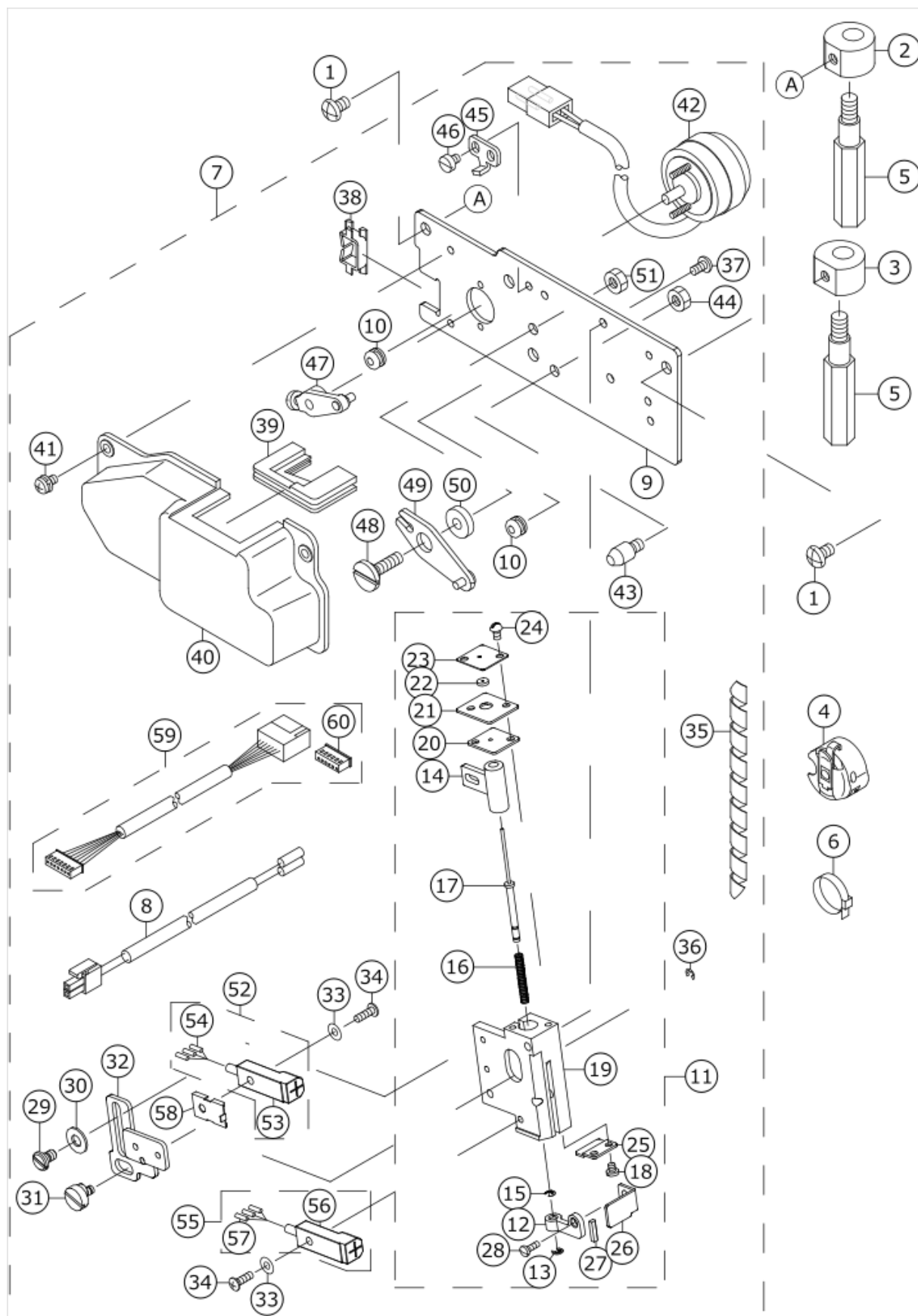

No.	品番	品名	備考	子部品	消耗品	個数
1	SS4110715SP	SCREW 11/64-40 L=7				2.00
2	GAE03041000	STATOR B LEFT				1.00
3	GAE03040000	BASE PLATE				1.00
4	GAE030450A0	BOBBIN CASE				1.00
5	GAE03042000	BED SCREW STUD				2.00
6	EA9500B0100	CABLE BAND				3.00
7	40088226	DRIVE_DEVICE_ASSY				1.00
8	40091087	SOLENOID EXTENSION CORD ASSY		*		1.00
9	40088225	BASE_PLATE		*		1.00
10	40088228	CODE_BUSH		*		2.00
11	40088229	GUIDER_ASSY		*		1.00
12	GAE03023000	MAGNET PLATE		*		1.00
13	RE0150000K0	SNAP RING 1.5		*		1.00
14	GAE03021000	DETECTING ROD HOLDER		*		1.00
15	GAE03025000	E RING		*		1.00
16	GAE03022000	DETECTING ROD SPRING		*		1.00
17	GAE03020000	DETECTING ROD		*		1.00
18	SS7060310SP	SCREW 3/32-56 L=3		*		2.00
19	40090415	GUIDER		*		1.00
20	GAE04027000	DETECTING ROD GUIDE PLATE		*		1.00
21	GAE04019000	DETECTING ROD FELT GUIDE		*		1.00
22	GAE03028000	DETECTING ROD FELT		*		1.00
23	GAE04029000	DETECTING ROD COVER		*		1.00
24	SS3060410SP	SCREW 3/32-56 L=4		*		2.00
25	40090419	DETECTING_ROD_STOPPER		*		1.00
26	40090417	L_CHECKER		*		1.00
27	40090418	SPACER		*		1.00
28	SS7060610SP	SCREW 3/32-56 L= 5.5		*		1.00
29	SD0400201SD	HINGE SCREW D= 4 H= 2		*		2.00
30	WP0450801SC	WASHER 4.5X10X0.8		*		2.00
31	GAE03032000	ECCENTRIC PIN		*		1.00
32	40090416	SENSOR_ADJUSTING_BRACKET		*		1.00
33	WP0280501SC	WASHER M2.6		*		2.00
34	SM0850801SC	SCREW M2.5 L=8		*		2.00
35	HX001890000	SPIRAL TUBE		*		1.00
36	RE0200000K0	E-RING		*		1.00
37	SS4080620TP	SCREW 1/8-44 L=6		*		2.00
38	HX00285000A	CORD HOLDER		*		1.00
39	GAE04039000	RUBBER CUSHION		*		1.00
40	GAE04038000	DRIVING EQUIPMENT COVER		*		1.00
41	SL4030681SC	SCREW M3 L=6		*		3.00
42	40084091	ROTARY SOLENOID ASSY		*		1.00
43	B1157781000	GUIDE PIN		*		1.00
44	NS6110420SP	NUT 11/64-40		*		1.00
45	GAE03018000	DRIVING LINK STOPPER A		*		1.00
46	SS6080410SP	SCREW 1/8-44 L=4		*		2.00
47	GAE030120A0	SOLENOID ARM ASM.		*		1.00
48	SD0790204SP	HINGE SCREW D= 7.94 H= 2		*		1.00
49	GAE040140A0	DRIVING LINK ASM.		*		1.00
50	MAO91003000	BSW PRESSER PLATE WASHER		*		1.00

51	NS6110420SP	NUT 11/64-40		*		1.00
52	40090489	PROXIMITY SENSOR ASSY		*		1.00
53	HD00286000A	PROXIMITY SENSOR		*		1.00
54	HK016540000	RECEPTABLE CONTACT		*		3.00
55	40090488	PROXIMITY SENSOR ASSY		*		1.00
56	HD002860000	PROXIMITY SENSOR		*		1.00
57	HK016540000	RECEPTABLE CONTACT		*		3.00
58	40091147	SENSOR BRACKET		*		1.00
59	40084059	LOWER THREAD SENSOR CORD ASSY		*		1.00
60	HK016510060	CONNECTOR HOUSING		*		1.00

STACKER COMPONENTS (1)

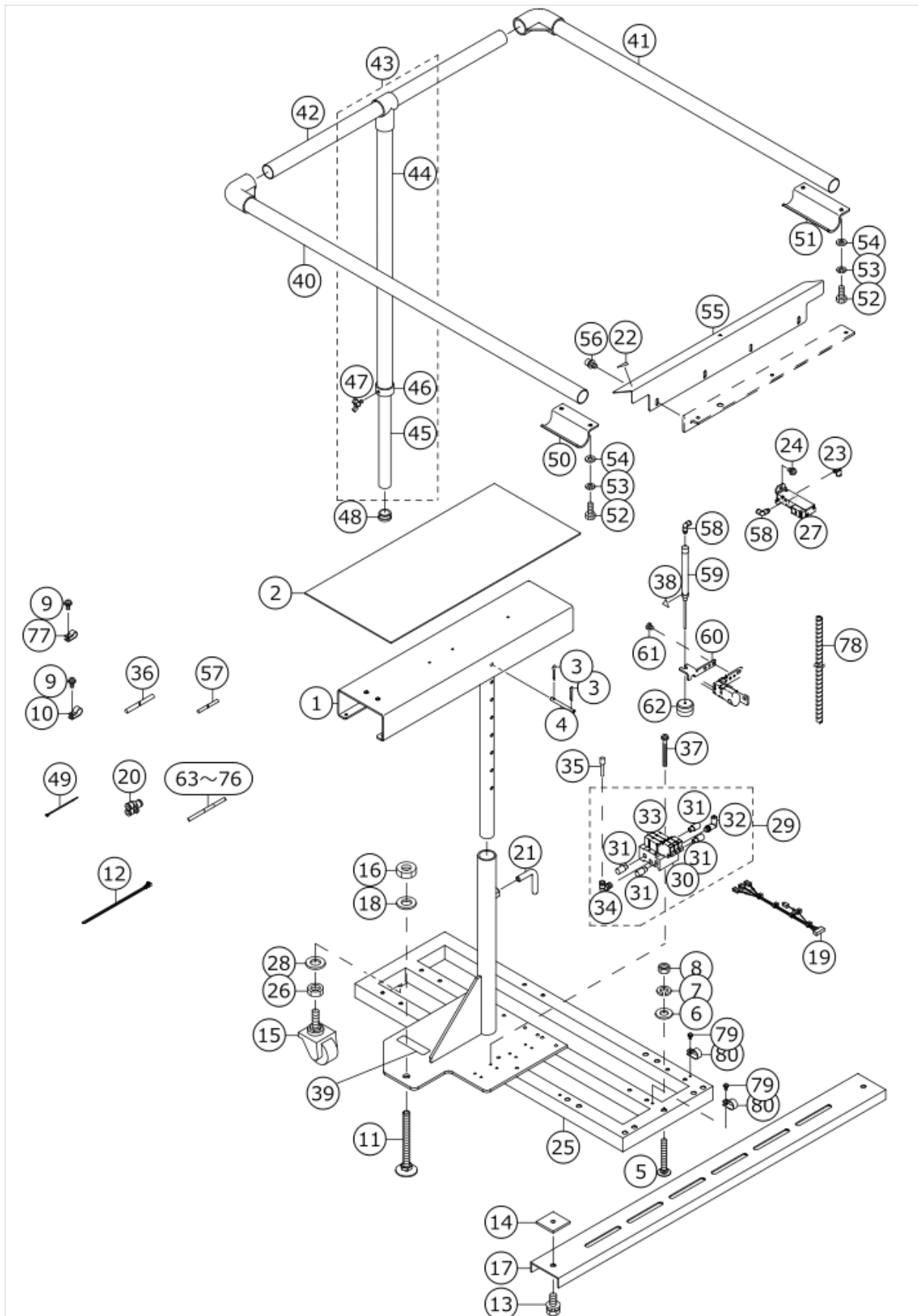

No.	品番	品名	備考	子部品	消耗品	個数
1	40088232	SUPPORT_BASE				1.00
2	GSS31121N00	SUPPORT BASE RUBBER				1.00
3	PD02010000B	SPLIT PIN				2.00
4	GST20004000	STOPPER PIN				1.00
5	MAS10704000	BOLT				3.00
6	WP1052001SC	WASHER 10,5X21X2				3.00
7	WS1020002KN	SPRING WASHER M10				3.00
8	NS6240630SP	NUT 3/8-18				3.00
9	SL4041091SC	SCREW M4 L=10				2.00
10	HX00150000F	CABLE CLIP				1.00
11	B8103WP3000A	ADJUSTING SCREW				1.00
12	HX002920000	BAND				1.00
13	SL9082091SE	WASHER HEXAGONAL BOLT				2.00
14	17007402	NUT				2.00
15	11152204	CASTER, SMALL				1.00
16	NM6120003SE	NUT M12				1.00
17	11158409	STAND SIDE SUPPORT				1.00
18	WP1302501SC	WASHER 13X24X2.5				1.00
19	40084082	VALVE CORD 2 ASSY				1.00
20	PJ308060003	Y UNION				2.00
21	GSS31171N00	SETTLE HANDLE				1.00
22	CM300200002	CAUTION LABEL(25)				1.00
23	PJ304060501	ELBOW				1.00
24	SL4040891SC	SCREW M4 L=8				2.00
25	40088233	STACKER_BASE				1.00
26	NM6120003SE	NUT M12				1.00
27	PV130540000	3-PORT SOLENOID VALVE				1.00
28	WP1302501SC	WASHER 13X24X2.5				1.00
29	40040527	MANIFOLD_VALVE_ASSY				1.00
30	PV035161000	MANIFOLD		*		1.00
31	PX055104000	SILENCER (PT1/8)		*		4.00
32	PJ304065101	ELBOW UNION 6XPT1/8		*		1.00
33	PV150104000	5-PORT SOKENOID VALVE		*		3.00
34	PJ304045102	ELBOW UNION, C		*		1.00
35	PX500014000	PLUG				1.00
36	BT0600401EB	TUBE				2.00
37	SL4044091SE	SCREW M4 L=40				4.00
38	CM300200001	ATTENTION SEAL				1.00
39	40093453	COMPLETE_NAME_LABEL_SS52_V				1.00
40	40088236	SAFETY_BAR_A_ASM.				1.00
41	40088238	SAFETY_BAR_B_ASM.				1.00
42	40088240	SAFETY_BAR_C				1.00
43	GSS294010A0	SAFETY BAR F ASM.				1.00
44	GSS292060A0	SAFETY BAR D ASM.		*		1.00
45	GSS29208000	SAFETY BAR E		*		1.00
46	GSS29401000	SAFETY FIXING RING		*		1.00
47	16137804	WING SCREW		*		1.00
48	TA2050805R0	RUBBER PLUG				1.00
49	EA9500B0100	CABLE BAND				10.00
50	GSS29201000	SAFETY BAR INSTALLING PLATE A				1.00

51	40088235	SAFETY_BAR_INSTALLING_PLATE				1.00
52	SM9061613SC	SCREW M6 L=16				4.00
53	WS0610002KN	SPRING WASHER 6.1X12.2X1.5				4.00
54	WP0641601SD	WASHER M6				4.00
55	40088234	SUPPORT_PLATE				1.00
56	SL6051092TN	BOLT				4.00
57	BT0400251EB	URETHANE HOSE, BLACK				1.00
58	PJ304040504	ELBOW UNION				2.00
59	PA1004505A0	CYLINDER				1.00
60	40088193	CLOTH_HOLD_PLATE				1.00
61	SS7110510SP	SCREW 11/64-40 L=5				2.00
62	18072553	THREAD CUTTER SUPPORT ASM.				1.00
63	18036707	WIRE MARK (18)				2.00
64	18036806	WIRE MARK (19)				2.00
65	18036905	WIRE MARK (20)				4.00
66	18037002	WIRE MARK (21)				4.00
67	18037101	WIRE MARK (22)				4.00
68	18037200	WIRE MARK (23)				4.00
69	18037309	WIRE MARK (24)				4.00
70	18037408	WIRE MARK (25)				4.00
71	18037507	WIRE MARK 26				4.00
72	18037606	WIRE MARK 27				4.00
73	18038000	WIRE MARK (31)				4.00
74	18038109	WIRE MARK (32)				4.00
75	18038208	WIRE MARK (33)				4.00
76	18038307	WIRE MARK (34)				4.00
77	HX00150000D	CABLE CLIP				1.00
78	HX00314000A	SPIRAL TUBE				2.00
79	HX00150000H	CABLE CLAMP				2.00
80	SL4041091SC	SCREW M4 L=10				2.00

STACKER COMPONENTS (2)

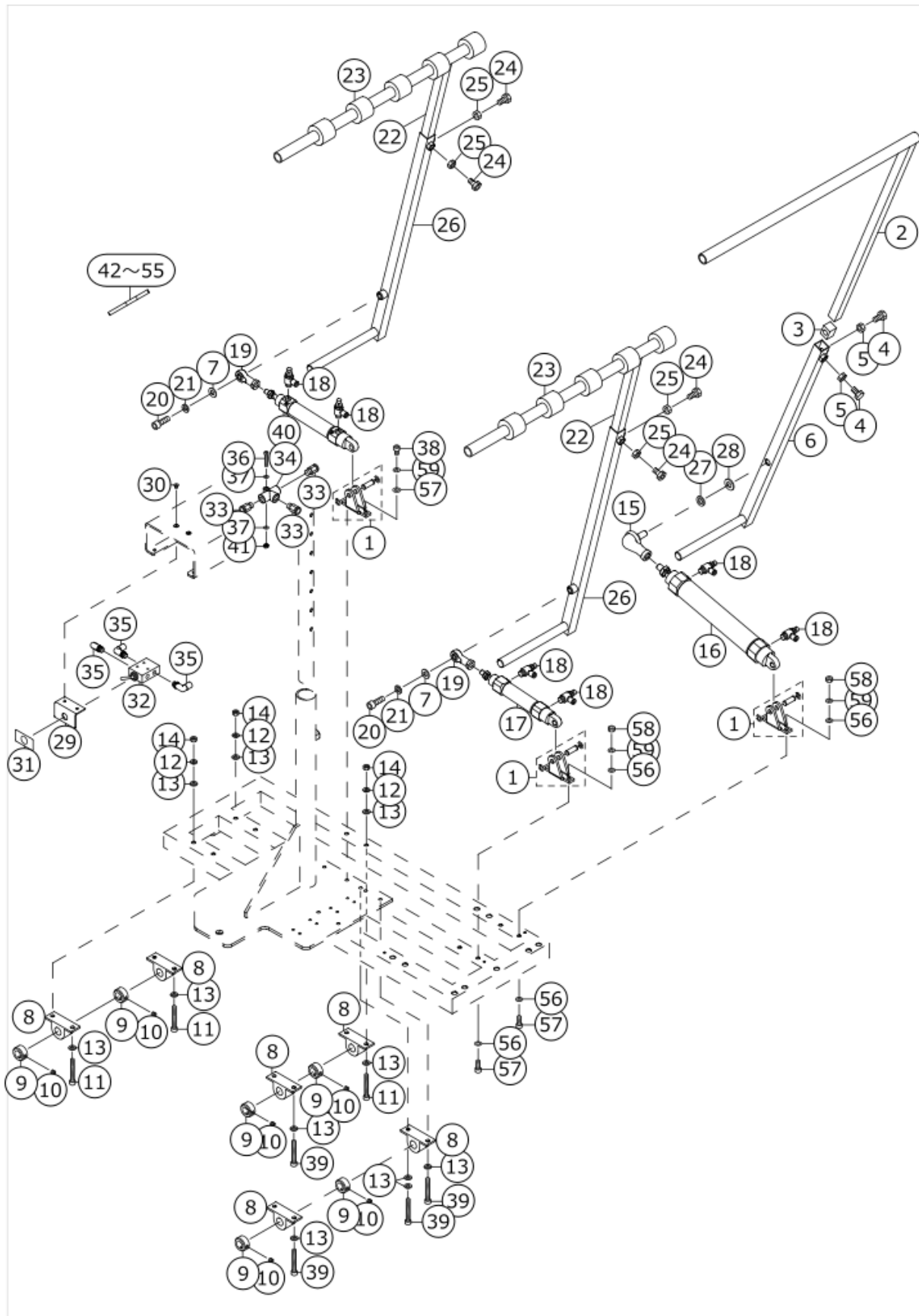

No.	品番	品名	備考	子部品	消耗品	個数
1	PA900053000	BRACKET				3.00
2	GSS29121000	WIPER, UPPER				1.00
3	40088242	SLIDE BLOCK				1.00
4	SM9081603SC	HEXAGONAL HEAD SCREW				2.00
5	NM6080003SC	NUT M8				2.00
6	GSS29303NA0	CLOTH FEED ASM.				1.00
7	WP0841601SC	WASHER 8.4X17.4X1.6				2.00
8	16136806	MINI PILLOW UNIT				6.00
9	CS1501181TP	THRUST COLLAR D=15 W=11				6.00
10	SM8050412TP	SCREW M5 L=4				6.00
11	SM6064502TP	SCREW M6 L=45				12.00
12	WS0610002KN	SPRING WASHER 6.1X12.2X1.5				6.00
13	WP0621016SD	WASHER 6.2X13X1				19.00
14	NM6060001SC	NUT M6				6.00
15	GSS29125000	LINK BALL				1.00
16	PA3215001A0	AIR CYLINDER				1.00
17	PA2005018A0	AIR CYLINDER				1.00
18	PC015108000	SPEED CONTROLLER				6.00
19	16138109	ROD				2.00
20	SM6082502TP	SCREW M8 L=25				2.00
21	WS0820002KN	SPRING WASHER M8				2.00
22	GSS31152N00	PRESSER ARM, UPPER				2.00
23	GAS11154000	STACKER RING				10.00
24	SM9081603SC	HEXAGONAL HEAD SCREW				4.00
25	NM6080003SC	NUT M8				4.00
26	GSS29300NA0	PRESSER ARM, LOWER A ASM.				2.00
27	WS1020002KN	SPRING WASHER M10				1.00
28	WP1052001SC	WASHER 10,5X21X2				1.00
29	G7523870000	STACK OPEN SWITCH FITTING PLATE				1.00
30	SM1040601SC	SCREW M4X0.7 L=6				2.00
31	G5519164000	STACKER OPEN SWITCH LABEL				1.00
32	PV015110000	AIR VALVE				1.00
33	PJ301045101	HALF UNION				3.00
34	PV205101000	SHUTTLE VALVE				1.00
35	PJ304045102	ELBOW UNION, C				3.00
36	SM6042502TN	SCREW M4X0.7 L=25				1.00
37	WP0430801SC	WASHER 4.3X9X0.8				2.00
38	SM6061202TP	SCREW M6 L=12				2.00
39	SM6064002TP	SCREW M6 L=40				6.00
40	PA2007509A0	AIR CYLINDER				1.00
41	NM6040001SC	NUT M4				1.00
42	18036707	WIRE MARK (18)				2.00
43	18036806	WIRE MARK (19)				2.00
44	18036905	WIRE MARK (20)				4.00
45	18037002	WIRE MARK (21)				4.00
46	18037101	WIRE MARK (22)				4.00
47	18037200	WIRE MARK (23)				4.00
48	18037309	WIRE MARK (24)				4.00
49	18037408	WIRE MARK (25)				4.00
50	18037507	WIRE MARK 26				4.00

51	18037606	WIRE MARK 27				4.00
52	18038000	WIRE MARK (31)				4.00
53	18038109	WIRE MARK (32)				4.00
54	18038208	WIRE MARK (33)				4.00
55	18038307	WIRE MARK (34)				4.00
56	WP0641601SC	WASHER				10.00
57	SM6061602TP	SCREW M6 L=16				4.00
58	NM6060001SC	NUT M6				4.00
59	WS0610002KN	SPRING WASHER 6.1X12.2X1.5				6.00

CLOTH TABLE COMPONENTS

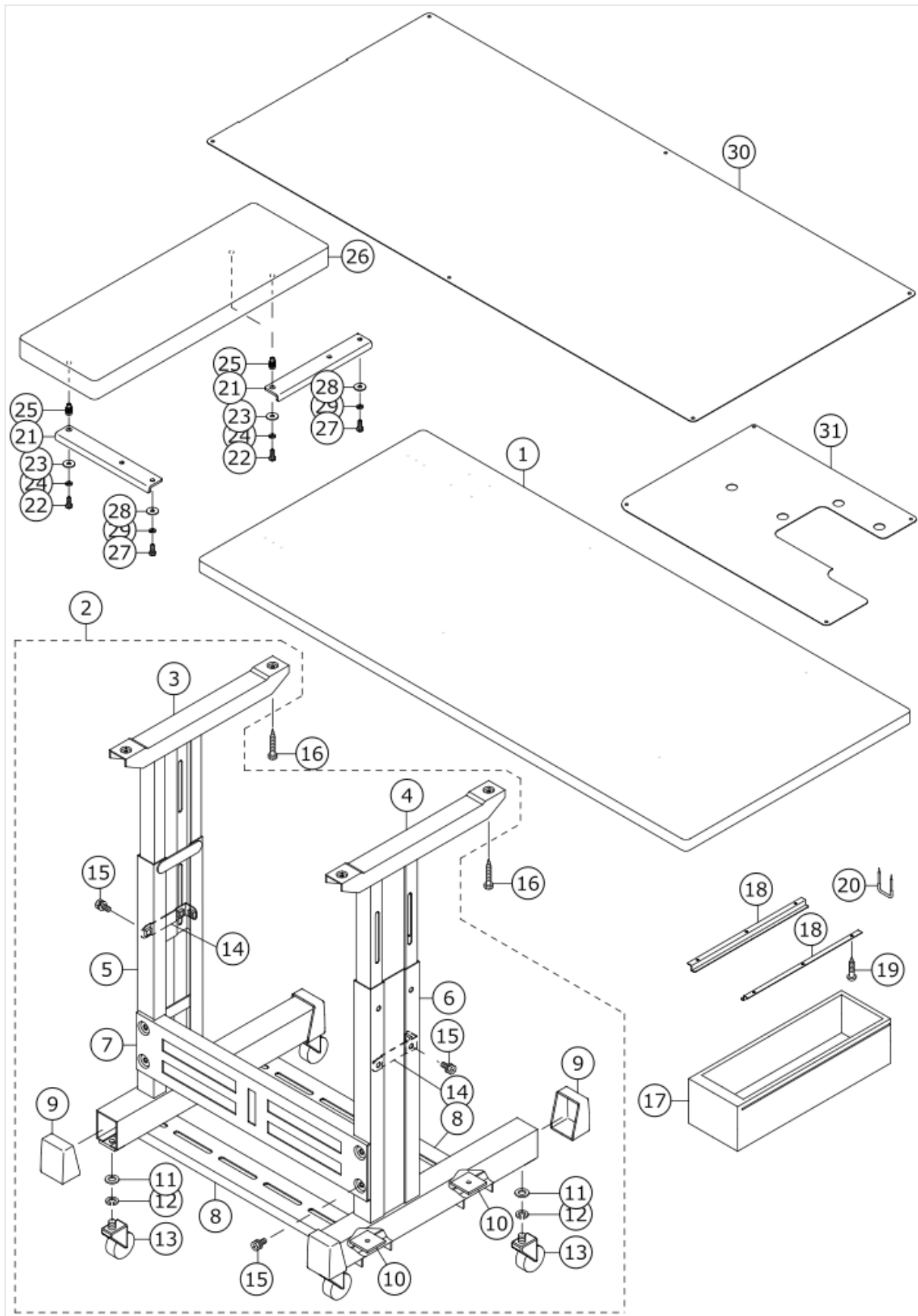

No.	品番	品名	備考	子部品	消耗品	個数
1	40088183	CLOTH_TABLE				1.00
2	40082280	T_STAND_ASSY				1.00
3	11157666	UPPER STAND ASM., RIGHT		*		1.00
4	11157765	UPPER STAND ASM., LEFT		*		1.00
5	11157963	LOWER LEG, RIGHT		*		1.00
6	11158060	LOWER LEG, LEFT		*		1.00
7	D8308205K0A	STAND SIDE SUPPORT		*		1.00
8	40082274	STAND_SIDE_SUPPORT_ADD		*		2.00
9	11158607	RUBBER CAP		*		4.00
10	17007402	NUT		*		4.00
11	WP1302501SE	WASHER M12		*		4.00
12	WS1253010KN	SPRING WASHER 12.5X21.5X3		*		4.00
13	17007204	CASTER		*		4.00
14	11158516	UPPER STAND PLATE		*		2.00
15	SL9082091SE	WASHER HEXAGONAL BOLT		*		14.00
16	SK3512001SE	WOOD SCREW D=5.1 L=20				4.00
17	11155108	DRAWER				1.00
18	11155207	DRAWER SUPPORT				2.00
19	SK3311601SE	WOOD SCREW D=3.1 L=16				6.00
20	D8204555D00	DRAWER STOPPER				1.00
21	18073700	CONNECTING PLATE				3.00
22	SM9061613SC	SCREW M6 L=16				6.00
23	WP0651646SC	WASHER				6.00
24	WS0610002KN	SPRING WASHER 6.1X12.2X1.5				6.00
25	40075287	INSERT_NUT M6X20				3.00
26	40088181	SUB_TABLE				1.00
27	SM9061613SC	SCREW M6 L=16				3.00
28	WP0651646SC	WASHER				3.00
29	WS0610002KN	SPRING WASHER 6.1X12.2X1.5				3.00
30	40096909	SUB_TABLE_COVER	OPTIONAL PARTS			1.00
31	40096969	TABLE_SLIPPER	OPTIONAL PARTS			1.00

BOBBIN WINDER & PEDAL COMPONENTS

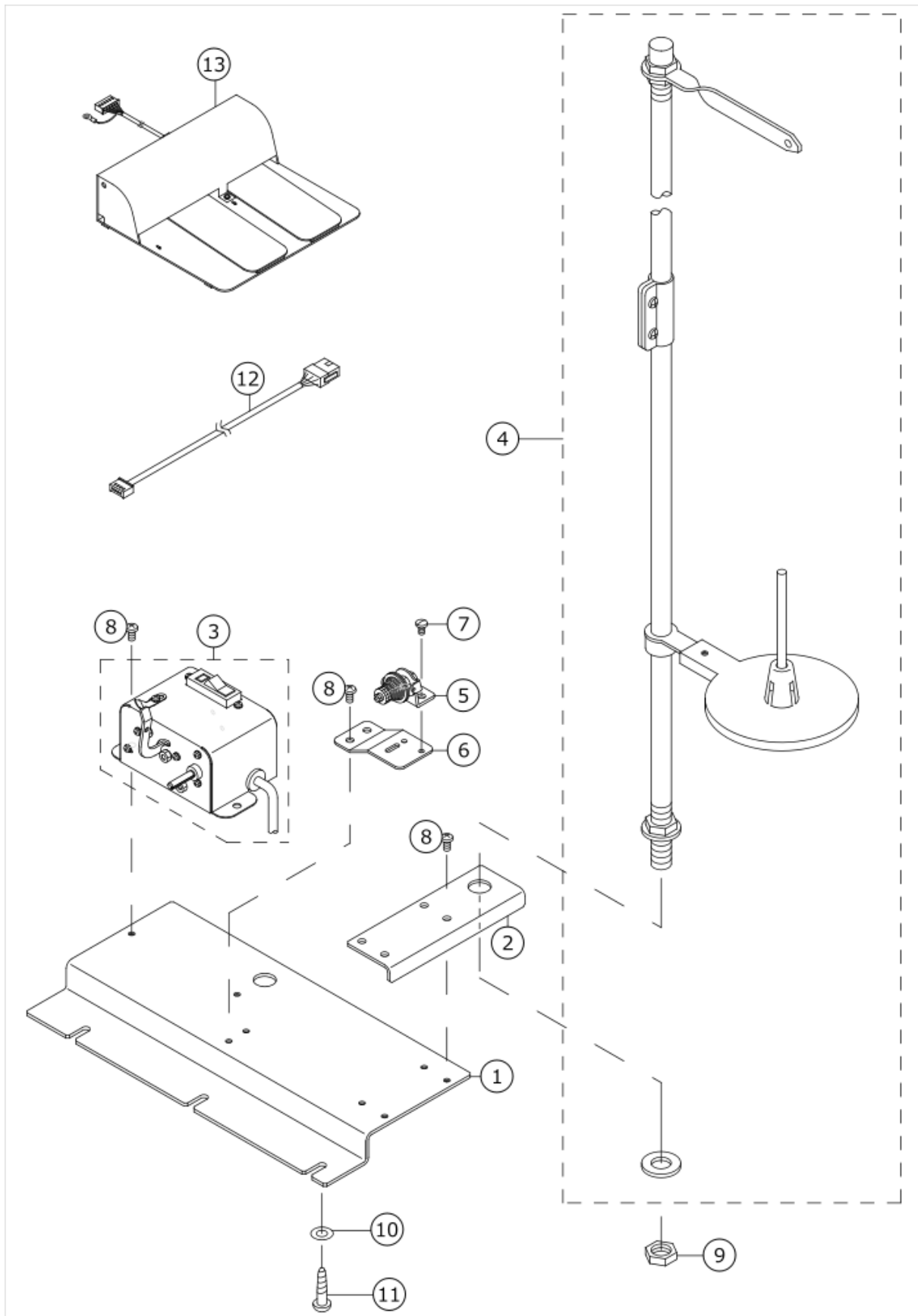

No.	品番	品名	備考	子部品	消耗品	個数
1	40089298	BOBBIN_DEVICE_INSTALLING_PLATE				1.00
2	40089299	THREAD_STAND_INSTALLING_PLATE				1.00
3	40188446	BOBBIN_WINDER_ASSY				1.00
4	26008359	THREAD STAND ASM.				1.00
5	13889951	BOBBIN GUIDE ASM.				1.00
6	G3216270000	BOBBIN BASE				1.00
7	SS7110840SP	SCREW 11/64-40 L=7.8				2.00
8	SM5051001SN	SCREW				8.00
9	NM6160511SE	NUT M16X1.5				1.00
10	WP0561616SC	WASHER 5.6X16X1.6				3.00
11	SK3512001SF	WOOD SCREW				3.00
12	40084086	BOBBIN WINDER CORD ASSY				1.00
13	40084064	PEDAL SWITCH ASM				1.00

CLOTH GUIDE & SENSOR COMPONENTS

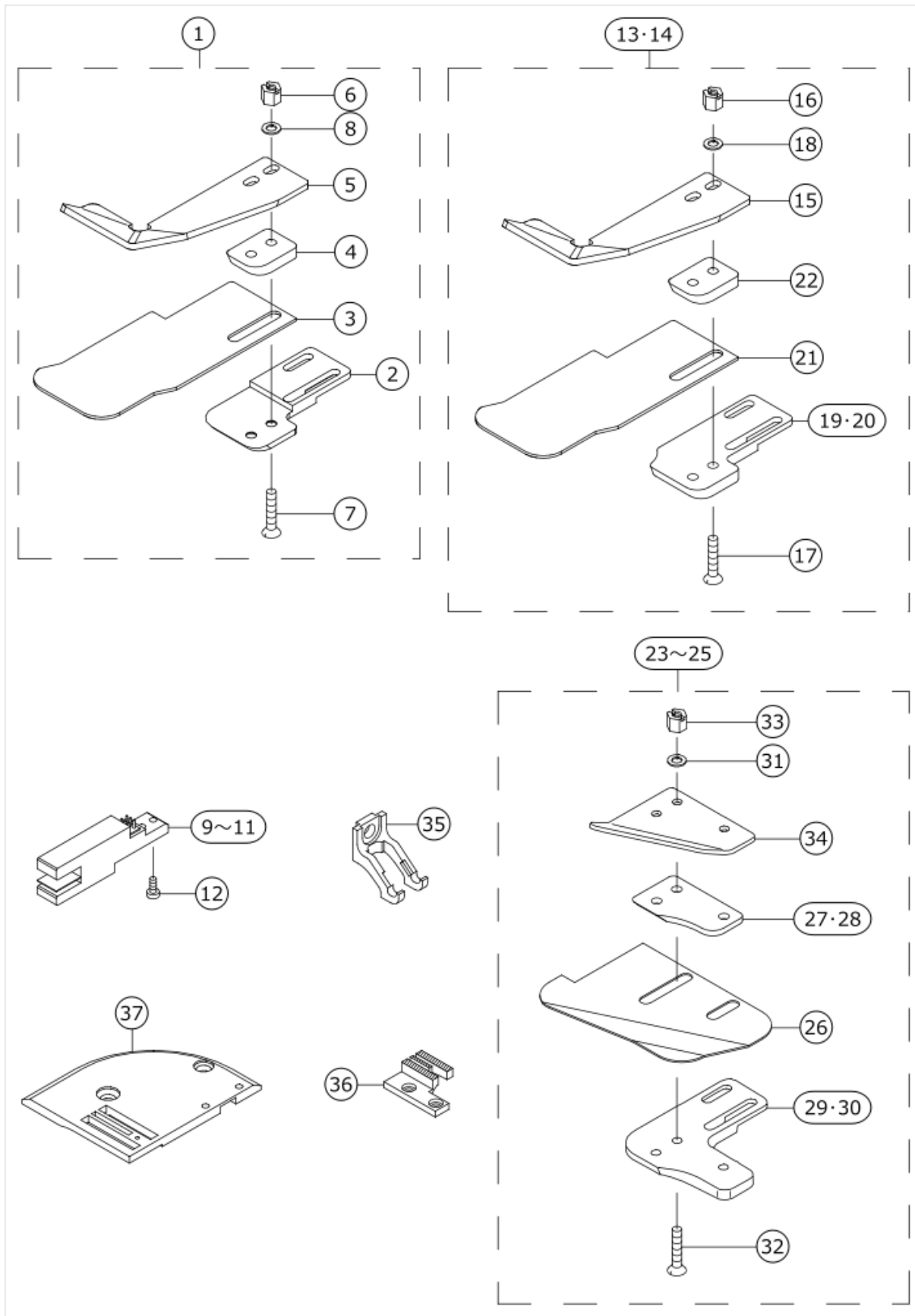

No.	品番	品名	備考	子部品	消耗品	個数
1	40088210	CLOTH_GUIDE_ASM_4/2	STANDARD PARTS			1.00
2	40088144	CLOTH_GUIDE_MOUNTING_BASE_(2MM)		*		1.00
3	18069500	CLOTH GUIDE SEPARATING PLATE		*		1.00
4	18051607	SEPARATING GUIDE A		*		1.00
5	18052100	SEPARATING GUIDE B		*		1.00
6	NM5030550SE	NUT M3X0.5		*		2.00
7	SM1031601SC	SCREW M3X0.5 L=16		*		2.00
8	WP03305000E	WASHER 3.3X6X0.5		*		2.00
9	40084100	EDGE SENSOR 4/2				1.00
10	40084101	EDGE SENSOR 4/4	TYPE 4/4			1.00
11	40084102	EDGE SENSOR 2/2	TYPE 2/2			1.00
12	SS6060510TP	SCREW 3/32-56 L=4.5	STANDARD PARTS			2.00
13	40088212	CLOTH_GUIDE_ASM_4/4	TYPE 4/4			1.00
14	40088211	CLOTH_GUIDE_ASM_2/2	TYPE 2/2			1.00
15	18052100	SEPARATING GUIDE B		*		1.00
16	NM5030550SE	NUT M3X0.5		*		2.00
17	SM1031601SC	SCREW M3X0.5 L=16		*		2.00
18	WP03305000E	WASHER 3.3X6X0.5		*		2.00
19	40088145	CLOTH_GUIDE_MOUNTING_BASE_(4MM)	TYPE 4/4	*		1.00
20	40088144	CLOTH_GUIDE_MOUNTING_BASE_(2MM)	TYPE 2/2	*		1.00
21	18069500	CLOTH GUIDE SEPARATING PLATE		*		1.00
22	18051607	SEPARATING GUIDE A		*		1.00
23	18076059	GUIDE ASM.	TYPE 2/2			1.00
24	18076257	GUIDE ASM.	TYPE 4/4			1.00
25	18076356	GUIDE ASM.	TYPE 4/2			1.00
26	18076109	SEPARATION PLATE E		*		1.00
27	18076000	SEPARATION GUIDE E	TYPE 2/2	*		1.00
28	18066704	SEPARATION GUIDE D	TYPE 4/4,4/2	*		1.00
29	18066506	GUIDE BASE E	TYPE 2/2,4/2	*		1.00
30	18066605	GUIDE BASE D	TYPE 4/4	*		1.00
31	WP03305000E	WASHER 3.3X6X0.5		*		2.00
32	SM1031401SE	SCREW M3X0.5 L=14		*		2.00
33	NM5030550SE	NUT M3X0.5		*		2.00
34	18066902	GUIDE D		*		1.00
35	40088215	UPPER_FEED_PRESSER(URETHANE)				1.00
36	22881700	FEED DOG A				1.00
37	40098871	THROAT_PLATE_A(THIN_USE)				1.00

HOW TO MAKE USE OF THIS PARTS LIST

- 1.As to "#01" and "#02" refer to the "Note" given at the bottom of the respective pages.
- 2.Codes on the "Qty" column
 - Each numeral indicates the number of parts required.
 - "0.1" and "2.5" indicate the length (in meters) of the respective parts.
- 3.Parentheses mean that the corresponding part is a subpart that constructs an assembly part.
- 4.Dotted lines on the Figures indicate assembly parts.
- 5.As to the parts with marks of "☆"(Consumable parts)and "◎"(optional parts)on the respective parts, it is recommended to prepare spares.

1. リストページの# 0 1、# 0 2の印は、ページ下の"注記"の説明を参照下さい。
2. 数量欄の数字は、個数を表し、0. 1、2. 5等の数値は、長さ（単位メートル）を表します。
3. 数量欄の（ ）は、組部品を構成している子部品であることを意味します。
4. イラストページの-----枠は、組構成であることを意味します。
5. リストページの"☆"（消耗部品）、"◎"（オプション部品）の印が付いた部品は、予備を準備しておくことをお奨めします。